

# QTD3020 총 조립도

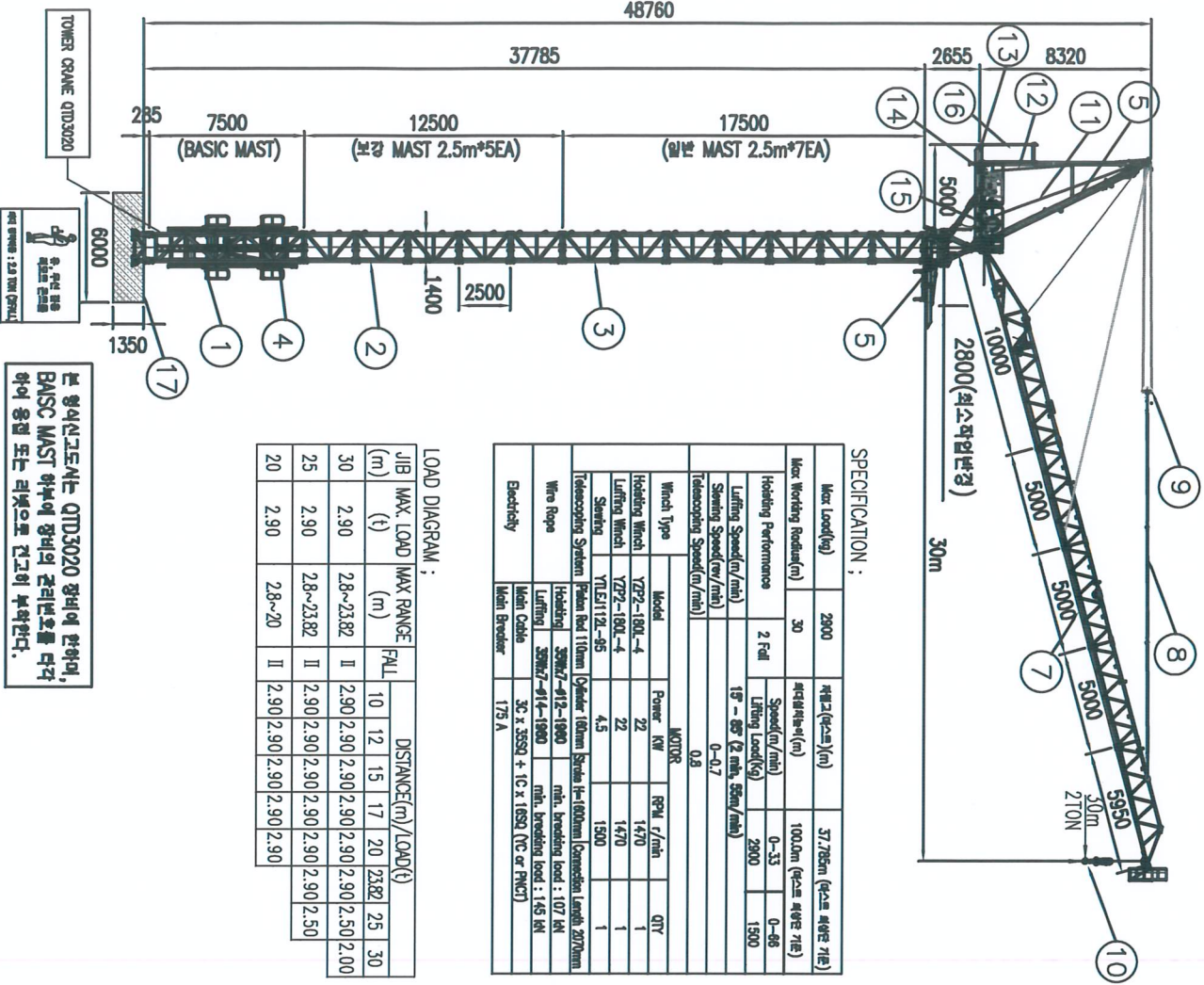

### SPECIFICATION :

Max Load(kg)	2000	적중량(적중량 기준)	37.76tn (적중량 기준 기준)
Max Working Radius(m)	30	적중거리(적중 기준)	100.0m (적중 기준 기준)
Holding Performance	2 Roll	Speed(m/min)	0-33
Lifting Speed(m/min)		Lifting Load(kg)	2000
Swinging Speed(m/min)			15° - 60° (2 m/s, 95m/min)
Telescoping Speed(m/min)			0-0.7
Winch Type	MOTOR		
Model	Y22-180-4	Power kW	22
Hoisting Winch	Y22-180-4	RPW t/min	14.70
Lifting Winch	Y1E112L-95		4.5
Swinging			1300
Telescoping System	Piano Rod (10mm) / Outer Rod (10mm) / Stroke (m) / (Compression Length) 2070mm		
Wire Rope	Hoisting 35M7-412-1800	min. breaking load : 107 kN	
	Lifting 35M7-412-1800	min. breaking load : 145 kN	
Electricity	Main Cable 3C x 35SQ + 1C x 16SQ (V or PVC)	Main Breaker 175 A	

### LOAD DIAGRAM :

JIB (m)	MAX LOAD (t)	MAX RANGE (m)	FALL (m)	DISTANCE(m)/LOAD(t)							
30	2.90	28~23.82	II	10	12	15	17	20	23.82	25	30
25	2.90	28~23.82	II	2.90	2.90	2.90	2.90	2.90	2.90	2.50	2.00
20	2.90	28~20	II	2.90	2.90	2.90	2.90	2.90	2.90	2.50	2.00

본 형식인고도서는 QTD3020 형식에 한하여, BASIC MAST 하부에 형체의 권리번호를 부착 하여 용접 또는 리벳으로 견고히 부착한다.

### 품명 LIST

NO.	품명	수량	중량(kg)	비고
1	BASIC MAST	1EA	2,960	
2	REINFORCED MAST (1,016 kg * 5EA)	5EA	5,080	
3	MAST (942 kg * 7EA)	7EA	6,594	
4	TELESCOPIC CRACK	1EA	2,888	
5	TURN TABLE	1EA	4,640	
6	A-RFRAME	1EA	2,423	
7	JIB SECTIONS (30m)	1SET	2,465	
8	JIB TIE BAR	1SET	358	
9	SHAKE BLOCK	1EA	180	
10	HOOK (27ALL 기어)	1EA	202	
11	HOST ROPE (WINCH용 포함)	1EA	0	
12	LUFFING ROPE (WINCH용 포함)	1EA	0	
13	C/JIB SECTION	1EA	3,328	
14	LUFFING WINCH	1EA	1,020	
15	HOST WINCH	1EA	860	
16	C/JIB BALLAST (4TON*1EA+2TON*5EA+1TON*2EA)	1SET	32,978	구조물 포함 (제일도 포함)
17	FOUNDATION CONCRETE(6m*6m*1.35m)	1EA	116,640	구조물 포함 (제일도 포함)
			161,618	전체 중량 (기조 포함)

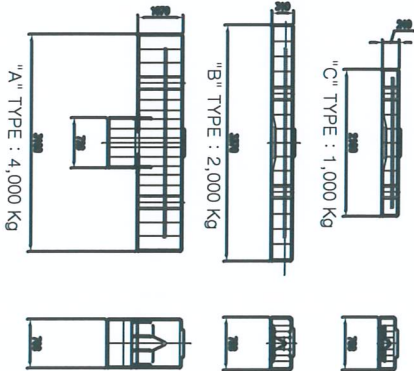
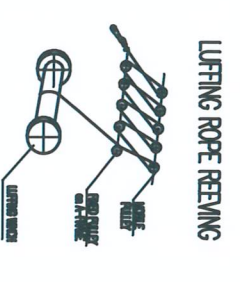
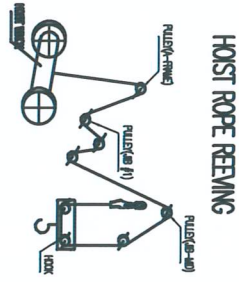

C/JIB	JIB	BLOCK	WEIGHT
1PIECE	30m	"A"*1EA+ "B"*3EA+ "C"*2EA	12,000
	25m	"A"*1EA+ "B"*3EA+ "C"*1EA	11,000
	20m	"A"*1EA+ "B"*3EA+	10,000

\* C/JIB WEIGHT \*  
 "A" TYPE : 4,000 Kg  
 "B" TYPE : 2,000 Kg  
 "C" TYPE : 1,000 Kg

NO.	DESCRIPTION	SIZE	MATERIAL
NO.	DRWING	DESIGN	CHECK
NO.	DATE	SCALE	1/9
(주)하이웍스		CUSTOMER	QTD3020 총 조립도
DRAWING		CHECK	APPROVAL
DATE		SCALE	1/9
DRAWING		CHECK	APPROVAL
DATE		SCALE	1/9
(주)하이웍스		CUSTOMER	QTD3020 총 조립도
DRAWING		CHECK	APPROVAL
DATE		SCALE	1/9
DRAWING		CHECK	APPROVAL
DATE		SCALE	1/9
(주)하이웍스		CUSTOMER	QTD3020 총 조립도
DRAWING		CHECK	APPROVAL
DATE		SCALE	1/9
DRAWING		CHECK	APPROVAL
DATE		SCALE	1/9
(주)하이웍스		CUSTOMER	QTD3020 총 조립도
DRAWING		CHECK	APPROVAL
DATE		SCALE	1/9
DRAWING		CHECK	APPROVAL
DATE		SCALE	1/9
(주)하이웍스		CUSTOMER	QTD3020 총 조립도
DRAWING		CHECK	APPROVAL
DATE		SCALE	1/9
DRAWING		CHECK	APPROVAL
DATE		SCALE	1/9
(주)하이웍스		CUSTOMER	QTD3020 총 조립도
DRAWING		CHECK	APPROVAL
DATE		SCALE	1/9
DRAWING		CHECK	APPROVAL
DATE		SCALE	1/9
(주)하이웍스		CUSTOMER	QTD3020 총 조립도
DRAWING		CHECK	APPROVAL
DATE		SCALE	1/9
DRAWING		CHECK	APPROVAL
DATE		SCALE	1/9
(주)하이웍스		CUSTOMER	QTD3020 총 조립도
DRAWING		CHECK	APPROVAL
DATE		SCALE	1/9
DRAWING		CHECK	APPROVAL
DATE		SCALE	1/9
(주)하이웍스		CUSTOMER	QTD3020 총 조립도
DRAWING		CHECK	APPROVAL
DATE		SCALE	1/9
DRAWING		CHECK	APPROVAL
DATE		SCALE	1/9
(주)하이웍스		CUSTOMER	QTD3020 총 조립도
DRAWING		CHECK	APPROVAL
DATE		SCALE	1/9
DRAWING		CHECK	APPROVAL
DATE		SCALE	1/9
(주)하이웍스		CUSTOMER	QTD3020 총 조립도
DRAWING		CHECK	APPROVAL
DATE		SCALE	1/9
DRAWING		CHECK	APPROVAL
DATE		SCALE	1/9
(주)하이웍스		CUSTOMER	QTD3020 총 조립도
DRAWING		CHECK	APPROVAL
DATE		SCALE	1/9
DRAWING		CHECK	APPROVAL
DATE		SCALE	1/9
(주)하이웍스		CUSTOMER	QTD3020 총 조립도
DRAWING		CHECK	APPROVAL
DATE		SCALE	1/9
DRAWING		CHECK	APPROVAL
DATE		SCALE	1/9
(주)하이웍스		CUSTOMER	QTD3020 총 조립도
DRAWING		CHECK	APPROVAL
DATE		SCALE	1/9
DRAWING		CHECK	APPROVAL
DATE		SCALE	1/9
(주)하이웍스		CUSTOMER	QTD3020 총 조립도
DRAWING		CHECK	APPROVAL
DATE		SCALE	1/9
DRAWING		CHECK	APPROVAL
DATE		SCALE	1/9
(주)하이웍스		CUSTOMER	QTD3020 총 조립도
DRAWING		CHECK	APPROVAL
DATE		SCALE	1/9
DRAWING		CHECK	APPROVAL
DATE		SCALE	1/9
(주)하이웍스		CUSTOMER	QTD3020 총 조립도
DRAWING		CHECK	APPROVAL
DATE		SCALE	1/9
DRAWING		CHECK	APPROVAL
DATE		SCALE	1/9
(주)하이웍스		CUSTOMER	QTD3020 총 조립도
DRAWING		CHECK	APPROVAL
DATE		SCALE	1/9
DRAWING		CHECK	APPROVAL
DATE		SCALE	1/9
(주)하이웍스		CUSTOMER	QTD3020 총 조립도
DRAWING		CHECK	APPROVAL
DATE		SCALE	1/9
DRAWING		CHECK	APPROVAL
DATE		SCALE	1/9
(주)하이웍스		CUSTOMER	QTD3020 총 조립도
DRAWING		CHECK	APPROVAL
DATE		SCALE	1/9
DRAWING		CHECK	APPROVAL
DATE		SCALE	1/9
(주)하이웍스		CUSTOMER	QTD3020 총 조립도
DRAWING		CHECK	APPROVAL
DATE		SCALE	1/9
DRAWING		CHECK	APPROVAL
DATE		SCALE	1/9
(주)하이웍스		CUSTOMER	QTD3020 총 조립도
DRAWING		CHECK	APPROVAL
DATE		SCALE	1/9
DRAWING		CHECK	APPROVAL
DATE		SCALE	1/9
(주)하이웍스		CUSTOMER	QTD3020 총 조립도
DRAWING		CHECK	APPROVAL
DATE		SCALE	1/9
DRAWING		CHECK	APPROVAL
DATE		SCALE	1/9
(주)하이웍스		CUSTOMER	QTD3020 총 조립도
DRAWING		CHECK	APPROVAL
DATE		SCALE	1/9
DRAWING		CHECK	APPROVAL
DATE		SCALE	1/9
(주)하이웍스		CUSTOMER	QTD3020 총 조립도
DRAWING		CHECK	APPROVAL
DATE		SCALE	1/9
DRAWING		CHECK	APPROVAL
DATE		SCALE	1/9
(주)하이웍스		CUSTOMER	QTD3020 총 조립도
DRAWING		CHECK	APPROVAL
DATE		SCALE	1/9
DRAWING		CHECK	APPROVAL
DATE		SCALE	1/9
(주)하이웍스		CUSTOMER	QTD3020 총 조립도
DRAWING		CHECK	APPROVAL
DATE		SCALE	1/9
DRAWING		CHECK	APPROVAL
DATE		SCALE	1/9
(주)하이웍스		CUSTOMER	QTD3020 총 조립도
DRAWING		CHECK	APPROVAL
DATE		SCALE	1/9
DRAWING		CHECK	APPROVAL
DATE		SCALE	1/9
(주)하이웍스		CUSTOMER	QTD3020 총 조립도
DRAWING		CHECK	APPROVAL
DATE		SCALE	1/9
DRAWING		CHECK	APPROVAL
DATE		SCALE	1/9
(주)하이웍스		CUSTOMER	QTD3020 총 조립도
DRAWING		CHECK	APPROVAL
DATE		SCALE	1/9
DRAWING		CHECK	APPROVAL
DATE		SCALE	1/9
(주)하이웍스		CUSTOMER	QTD3020 총 조립도
DRAWING		CHECK	APPROVAL
DATE		SCALE	1/9
DRAWING		CHECK	APPROVAL
DATE		SCALE	1/9
(주)하이웍스		CUSTOMER	QTD3020 총 조립도
DRAWING		CHECK	APPROVAL
DATE		SCALE	1/9
DRAWING		CHECK	APPROVAL
DATE		SCALE	1/9
(주)하이웍스		CUSTOMER	QTD3020 총 조립도
DRAWING		CHECK	APPROVAL
DATE		SCALE	1/9
DRAWING		CHECK	APPROVAL
DATE		SCALE	1/9
(주)하이웍스		CUSTOMER	QTD3020 총 조립도
DRAWING		CHECK	APPROVAL
DATE		SCALE	1/9
DRAWING		CHECK	APPROVAL
DATE		SCALE	1/9
(주)하이웍스		CUSTOMER	QTD3020 총 조립도
DRAWING		CHECK	APPROVAL
DATE		SCALE	1/9
DRAWING		CHECK	APPROVAL
DATE		SCALE	1/9
(주)하이웍스		CUSTOMER	QTD3020 총 조립도
DRAWING		CHECK	APPROVAL
DATE		SCALE	1/9
DRAWING		CHECK	APPROVAL
DATE		SCALE	1/9
(주)하이웍스		CUSTOMER	QTD3020 총 조립도
DRAWING		CHECK	APPROVAL
DATE		SCALE	1/9
DRAWING		CHECK	APPROVAL
DATE		SCALE	1/9
(주)하이웍스		CUSTOMER	QTD3020 총 조립도
DRAWING		CHECK	APPROVAL
DATE		SCALE	1/9
DRAWING		CHECK	APPROVAL
DATE		SCALE	1/9
(주)하이웍스		CUSTOMER	QTD3020 총 조립도
DRAWING		CHECK	APPROVAL
DATE		SCALE	1/9
DRAWING		CHECK	APPROVAL
DATE		SCALE	1/9
(주)하이웍스		CUSTOMER	QTD3020 총 조립도
DRAWING		CHECK	APPROVAL
DATE		SCALE	1/9
DRAWING		CHECK	APPROVAL
DATE		SCALE	1/9
(주)하이웍스		CUSTOMER	QTD3020 총 조립도
DRAWING		CHECK	APPROVAL
DATE		SCALE	1/9
DRAWING		CHECK	APPROVAL
DATE		SCALE	1/9
(주)하이웍스		CUSTOMER	QTD3020 총 조립도
DRAWING		CHECK	APPROVAL
DATE		SCALE	1/9
DRAWING		CHECK	APPROVAL
DATE		SCALE	1/9
(주)하이웍스		CUSTOMER	QTD3020 총 조립도
DRAWING		CHECK	APPROVAL
DATE		SCALE	1/9
DRAWING		CHECK	APPROVAL
DATE		SCALE	1/9
(주)하이웍스		CUSTOMER	QTD3020 총 조립도
DRAWING		CHECK	APPROVAL
DATE		SCALE	1/9
DRAWING		CHECK	APPROVAL
DATE		SCALE	1/9
(주)하이웍스		CUSTOMER	QTD3020 총 조립도
DRAWING		CHECK	APPROVAL
DATE		SCALE	1/9
DRAWING		CHECK	APPROVAL
DATE		SCALE	1/9
(주)하이웍스		CUSTOMER	QTD3020 총 조립도
DRAWING		CHECK	APPROVAL
DATE		SCALE	1/9
DRAWING		CHECK	APPROVAL
DATE		SCALE	1/9
(주)하이웍스		CUSTOMER	QTD3020 총 조립도
DRAWING		CHECK	APPROVAL
DATE		SCALE	1/9
DRAWING		CHECK	APPROVAL
DATE		SCALE	1/9
(주)하이웍스		CUSTOMER	QTD3020 총 조립도
DRAWING		CHECK	APPROVAL
DATE		SCALE	1/9
DRAWING		CHECK	APPROVAL
DATE		SCALE	1/9
(주)하이웍스		CUSTOMER	QTD3020 총 조립도
DRAWING		CHECK	APPROVAL
DATE		SCALE	1/9
DRAWING		CHECK	APPROVAL
DATE		SCALE	1/9
(주)하이웍스		CUSTOMER	QTD3020 총 조립도
DRAWING		CHECK	APPROVAL
DATE		SCALE	1/9
DRAWING		CHECK	APPROVAL

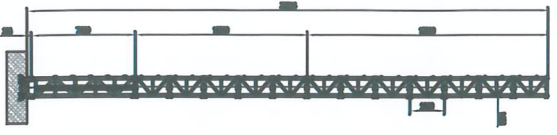

MAST COMPOSITION

Tipe	AB = 30m, 25m, 20m		
	7.2m	3.0m	3.0m
7.2m	1	0	0
10.2m	1	1	0
12.7m	1	2	0
15.2m	1	3	0
17.7m	1	4	0
20.2m	1	5	0
22.7m	1	5	1
25.2m	1	5	2
27.7m	1	5	3
30.2m	1	5	4
32.7m	1	5	5
35.2m	1	5	6
37.7m	1	5	7

(Catatan :  
1. 01 : Mast  
2. 02 : Mast  
3. 03 : Mast

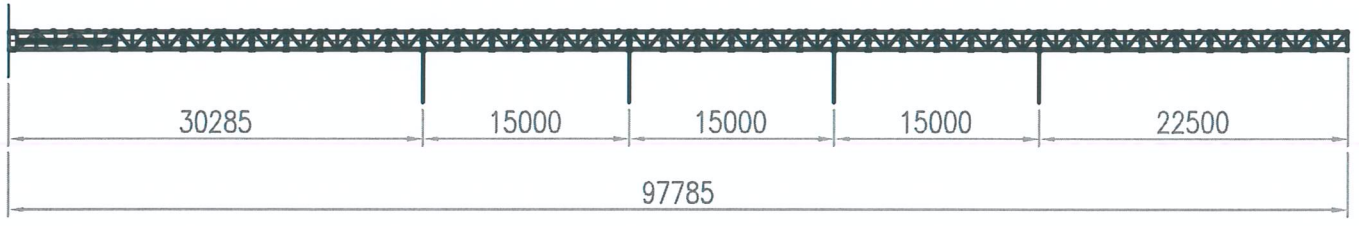

MAST OVERHANG : 9EA

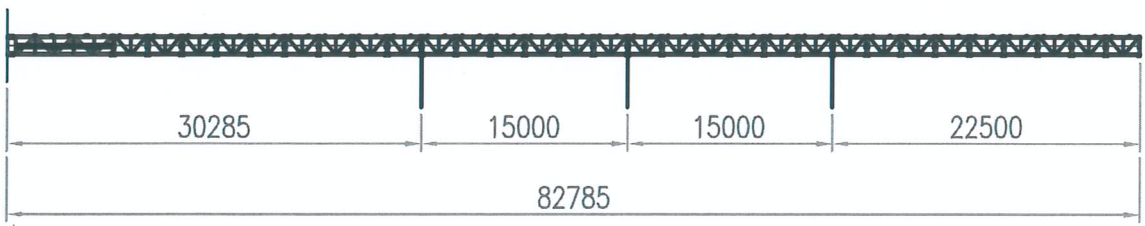

MAST OVERHANG : 9EA

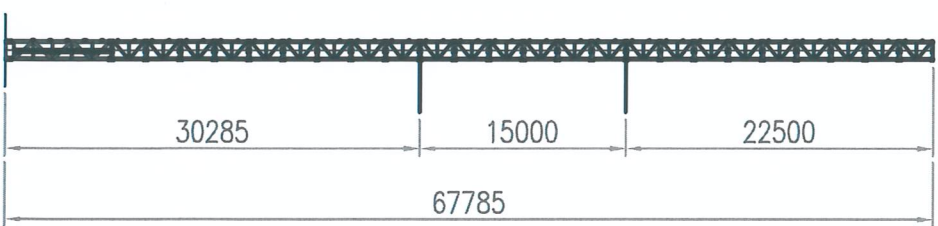

MAST OVERHANG : 9EA

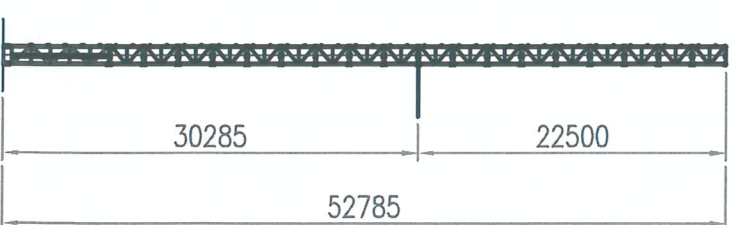

MAST OVERHANG : 9EA



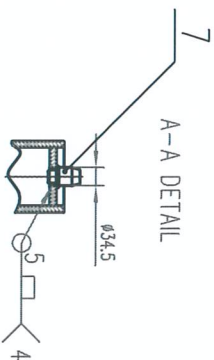
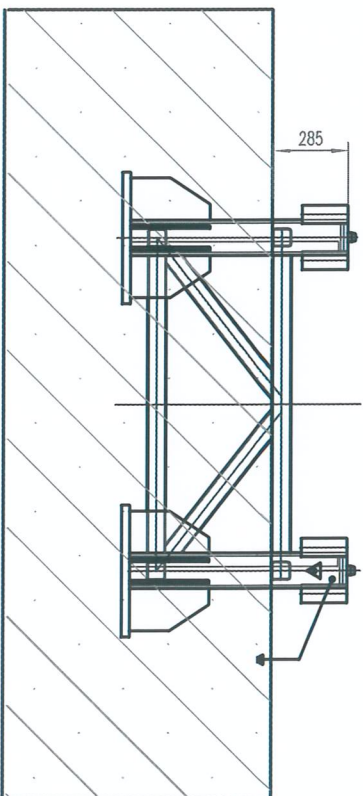
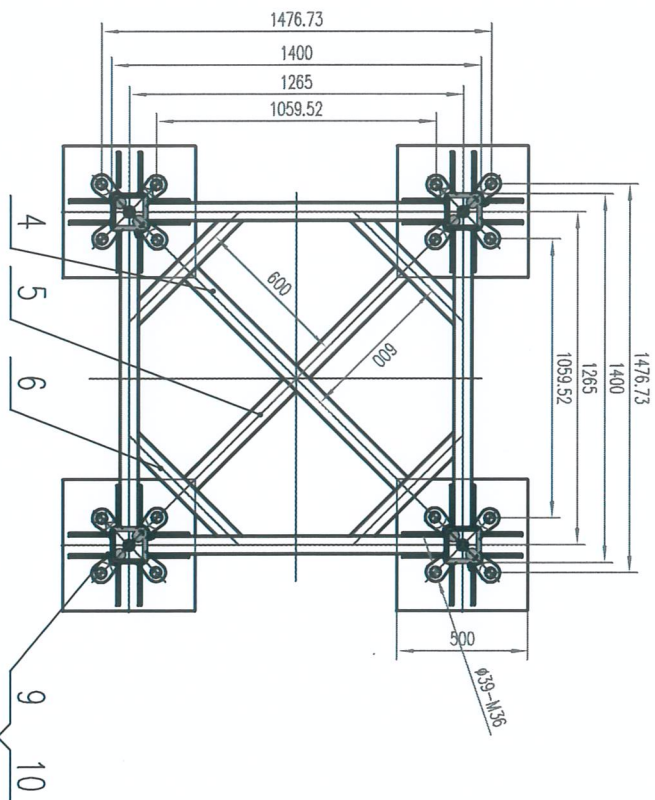
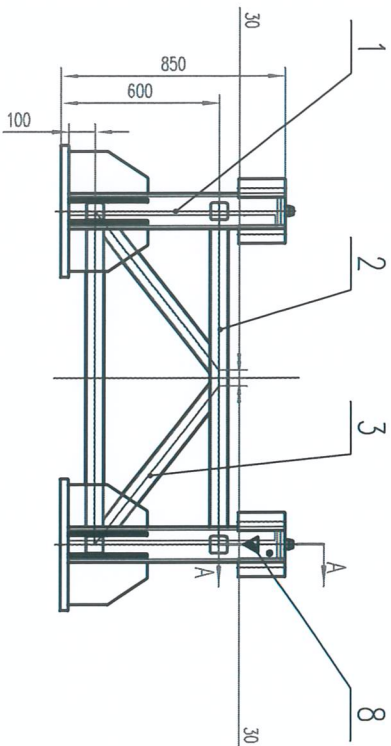

NO.	PARTS CODE	DESCRIPTION	QTY	MATERIAL	UNIT	TOTAL WEIGHT	REMARK
10	GB/T 6170-2000	nut M10	4		0.01	0.04	
9	GB/T 97.1-2002	washer 10	4		0.01	0.04	
8	QTD63.04-08	sign plate for earthing	4		0.02	0.08	
7	QTD63.01.01-07	location pin	4	Q345B	0.39	1.56	
6	QTD63.04-06	square pipe	4	Q345B	5.36	21.44	
5	QTD63.04-05	SQ-70X5-530	2	Q345B	5.41	10.82	
4	QTD63.04-04	SQ-70X5-1130	1	Q345B	11.54	11.54	
3	QTD63.04-03	SQUARE PIPE	8	Q345B	7.00	56.00	
2	QTD63.04-02	SQ-70X5-1130	8	Q345B	11.54	92.32	
1	QTD63.04.01	2L-125*12t	4	Q345B	144.6	578.40	MAIN CHOSED

FIXING ANGLES

QTD63.04

DRAWING NO.	WEIGHT	SCALE
	772.24	1:20

ASSEMBLY

SICHUAN SUNFLOWER MECHANICAL CO., LTD.

지시하지 않은 접합부는 얇은 쪽 모재 두께의 70% 각장으로 용접할 것.