

Turmdrehkran 100 LC

Tower Crane / Grue à tour / Gru a torre
Grúa torre / Guindaste de torre

※ 형식신고번호 5-27-0085-00-00 참조

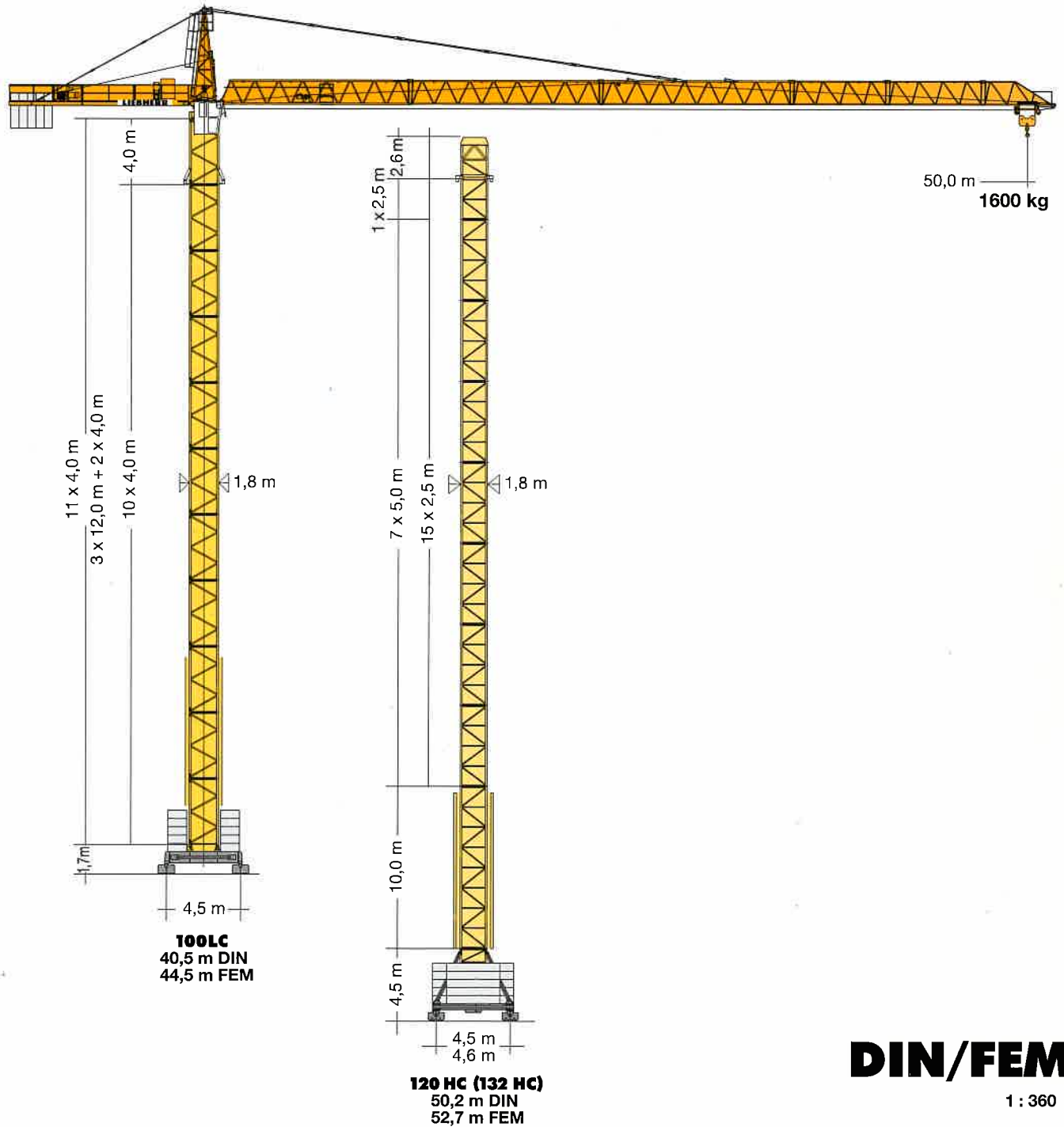

LIEBHERR

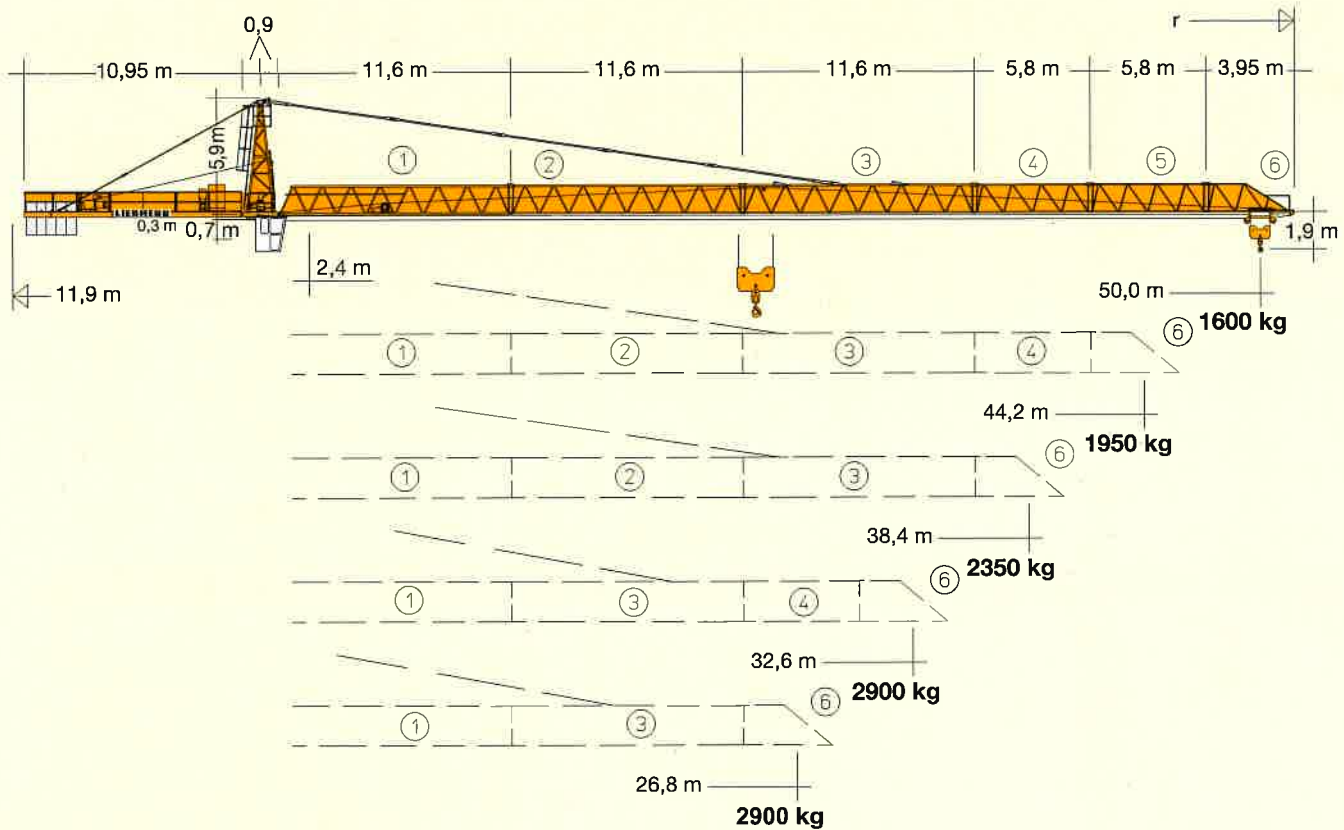

Gewicht

Weight / Poids / Peso / Peso / Pesos

Zentralballast / Central ballast
Lest de base / Zavorra centrale
Lastro central / Lastre central

65000 kg

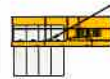

(Ausl. 50 m)

12750 kg



36900 kg

Hubhöhe

Hoisting height / Hauteur sous crochet / Altezza di sollevamento / Altura bajo gancho / Altura de montagem

| | | 100 LC | | | | |
|--------|------|--------|-------|-------|-------|-------|
| 4 m | 12 m | | | | | |
| 11 | | 44,5* | 44,4* | 44,1* | 43,1* | 55,2* |
| FEM 10 | | 40,5* | 40,4* | 40,1* | 39,1* | 51,2* |
| DIN 9 | 3 | 36,5 | 36,4 | 36,1 | 35,1 | 47,2 |
| 8 | | 32,5 | 32,4 | 32,1 | 31,1 | 43,2 |
| 7 | | 28,5 | 28,4 | 28,1 | 27,1 | 39,2 |
| 6 | 2 | 24,5 | 24,4 | 24,1 | 23,1 | 35,2 |
| 5 | | 20,5 | 20,4 | 20,1 | 19,1 | 31,2 |
| 4 | | 16,5 | 16,4 | 16,1 | 15,1 | 27,2 |
| 3 | 1 | 12,5 | 12,4 | 12,1 | 11,1 | 23,2 |
| 2 | | 8,5 | 8,4 | 8,1 | 7,1 | 19,2 |
| 1 | | 4,5 | 4,4 | 4,1 | 3,1 | 15,2 |
| 0 | | | | | | 11,2 |
| | | m | m | m | m | m |
| | | | | | | |



Weitere Hubhöhen auf Anfrage. / Further hoist heights on request. / Hauteurs sous crochet sur demande. / Altre altezze di sollevamento: su richiesta. / Outras alturas de elevação: conforme ao pedido. / Para alturas bajo gancho superiores, consultar.

** nicht kletterbar / not for climbing / non télescopable / non telescopabile / no trepable / no telescopabel

Ausladung und Tragfähigkeit

Radius and capacity / Portée et charge / Sbraccio e portata / Alcances y cargas / Alcance e capacidade de carga





| m | r | m/kg | m/kg | | | | | | | | | | | | | |
|------|------------|--------------------|------|------|------|------|------|------|------|------|------|------|------|------|------|------|
| | | | 16,0 | 18,0 | 20,0 | 22,0 | 24,0 | 26,8 | 30,0 | 32,6 | 36,0 | 38,4 | 42,0 | 44,2 | 48,0 | 50,0 |
| 50,0 | (r = 51,6) | 2,4 - 29,3 3000 | | | | | | 2900 | 2900 | 2660 | 2370 | 2200 | 1970 | 1860 | 1680 | 1600 |
| 44,2 | (r = 45,8) | 2,4 - 30,5 3000 | | | | | 2900 | 2900 | 2780 | 2480 | 2300 | 2070 | 1950 | | | |
| 38,4 | (r = 40,0) | 2,4 - 31,1 3000 | | | | | 2900 | 2900 | 2840 | 2530 | 2350 | | | | | |
| 32,6 | (r = 34,2) | 2,4 - 31,6 3000 | | | | | 2900 | 2900 | 2900 | | | | | | | |
| 26,8 | (r = 28,4) | 2,4 - 26,8 3000 | | | | | 2900 | | | | | | | | | |

















Hubhöhe

Hoisting height / Hauteur sous crochet / Altezza di sollevamento / Altura bajo gancho / Altura de montagem

| | | 120 HC (132 HC) | | | | |
|-----|----|-----------------|-------|-------|-------|-------|
| FEM | 15 | 52,7* | 52,2* | 48,4* | 49,9* | 49,7* |
| DIN | 14 | 50,2* | 49,7* | 45,9* | 47,4* | 47,2* |
| | 13 | 47,7 | 47,2 | 43,4 | 44,9 | 44,7 |
| | 12 | 45,2 | 44,7 | 40,9 | 42,4 | 42,2 |
| | 11 | 42,7 | 42,2 | 38,4 | 39,9 | 39,7 |
| | 10 | 40,2 | 39,7 | 35,9 | 37,4 | 37,2 |
| | 9 | 37,7 | 37,2 | 33,4 | 34,9 | 34,7 |
| | 8 | 35,2 | 34,7 | 30,9 | 32,4 | 32,2 |
| | 7 | 32,7 | 32,2 | 28,4 | 29,9 | 29,7 |
| | 6 | 30,2 | 29,7 | 25,9 | 27,4 | 27,2 |
| | 5 | 27,7 | 27,2 | 23,4 | 24,9 | 24,7 |
| | 4 | 25,2 | 24,7 | 20,9 | 22,4 | 22,2 |
| | 3 | 22,7 | 22,2 | 18,4 | 19,9 | 19,7 |
| | 2 | 20,2 | 19,7 | 15,9 | 17,4 | 17,2 |
| | 1 | 17,7 | 17,2 | 13,4 | 14,9 | 14,7 |
| | 0 | 15,2 | 14,7 | 10,9 | 12,4 | 12,2 |
| | | m | m | m | m | m |
| | | | | | | |

















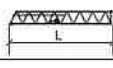

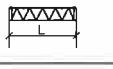

| | | |
|--|-------------------------------------|--|
|  | U/min 0 – 0,8 sl./min tr./min | 5,0 kW |
|  | 9,0 / 30,0 / 60,0 m/min | 0,65 / 2,0 / 3,0 kW |
|  | 18,0 m/min 25,0 m/min | 2 x 2,6 kW (100 LC) 2 x 4,0 kW (120 HC) |
|  | kVA | 22,0 kW 37,0 |

| | | | |
|---|--|------|-------|
|  | Stufe / Step Cran / Marcia Marcha / Marcha | kg | m/min |
| 3,8 / 18,5 / 22,0 kW | | | |
|  | 3 Lagen Layers Couches Strati Camadas Capas | | |
| 85,0 m LS-Trommel | | | |
| 1 |  | 3000 | 3000 |
| 2 |  | 3000 | 27,0 |
| 3 |  | 1800 | 56,0 |
| 1 |  | 6000 | 3,0 |
| 2 |  | 6000 | 13,5 |
| 3 |  | 3700 | 28,0 |
|  | 5 Lagen Layers Couches Strati Camadas Capas | | |
| 149,0 m LS-Trommel | | | |
| 1 |  | 3000 | 3000 |
| 2 |  | 3000 | 28,0 |
| 3 |  | 1700 | 58,0 |
| 1 |  | 6000 | 3,1 |
| 2 |  | 6000 | 14,0 |
| 3 |  | 3500 | 29,0 |

Kolli-Liste

Packing List / Liste de colisage / Lista dei colli / Lista de contenido / Lista de embalagem

Montagegewichte: siehe Betriebsanleitung. / Erection weights: see instruction manual. / Poids de montage: voir manuel de service.
Pesi di montaggio: vedasi le istruzioni sull'uso. / Pesos de montagem: vejarn-se es instruções p. uso. / Peso para el montaje: según manual.

| Kranoberteil | | Upper part of crane / Partie supérieure de grue / Parte superiore della gru Parte superior grúa / Parte superior do guindaste | L (m) | B (m) | H (m) | kg* | | |
|-------------------------------|---------------------------------|---|---|---|--------------------------------|------------------------------|------------------------------|------------------------------------|
| Pos. Item Rep. Voce Pos. Ref. | Anz. Qty. Qte. Qta. Cant. Cant. | Kabine + Steuerstand / Cabin + Seat Cabine + fauteuil / Cabina + poltrona Cabine + cadeira / Cabina + butaca |  |  | 1,87 | 1,12 | 2,18 | 440 |
| 1 | 1 | | | | | | | |
| 2 | 1 | Turmspitze / Tower head section Porte-flèche / Testa porta-braccio Cabeça de apoio de lança / Cabeza de torre |  |  | 5,62 | 1,16 | 1,57 | 740 |
| 3 | 1 | Gegenausleger / Counter-jib Contre-flèche / Contrabaccio Contra-lança / Contrapluma |  |  | 11,03 | 1,67 | 0,45 | 1480 |
| 4 | 1 | Ausleger-Anlenkstück / Jib heel section Pied de flèche / Settore articolato di braccio Base articulada de lança / Pluma tramo primero |  |  | 11,79 | 1,17 | 1,59 | ① 1520 |
| 5 | 1 | Ausleger-Zwischenstück / Intermediate jib section Elément interm. de flèche / Spezzone di braccio Peça suplementar da lança / Tramo intermedio pluma |  |  | 11,68 11,83 6,02 6,00 | 1,17 1,17 1,17 1,17 | 1,54 1,63 1,53 1,51 | ② 1060 ③ 1000 ④ 360 ⑤ 267 |
| 6 | 1 | Ausleger-Kopfstück / Jib head Pointe de flèche / Punta freccia Cabeça de lança / Tramo punta de pluma |  |  | 4,16 | 1,17 | 1,72 | ⑥ 230 |
| 7 | 1 | Podeste / Platforms Plates-formes / Piattaforma Plataforma / Plataforma |  |  | 1,68 | 0,33 | 1,82 | 166 |
| 8 | 1 | Laufkatze / Trolley Chariot / Carrello Carrinho / Carrito |  |  | 1,57 | 1,34 | 0,77 | 170 |
| 9 | 1 | Drehbühne mit Kud-Auflage / Slewing platform with slewing ring support Ensembles mât cabine avec pivot cage / Piattaforma girevole con supporto della ralla di rotazione / Plataforma giratória con suporte de corôa dentada / Asiento pista con plataforma giratoria |  |  | 1,60 | 2,01 | 1,93 | 2590 |
| 10 | 1 | Hubwerk / Winch Treuil / Verricello / Mecanismo elevatorio Mecanismo elevación carga |  |  | 1,50 | 1,36 | 0,71 | 655 |

Turm
Tower / Mât / Torre
Torre / Torre

| | | | | | | | | | |
|----|---|--|--|--|-------------|---------------|--------------|--------------|--------------|
| 11 | 1 | Turmstück / Tower section Element de mât / Elemento di torre Torre / Torre | | | 12 m 4 m | 12,27 4,27 | 1,80 1,80 | 1,80 1,90 | 2870 1105 |
| 12 | 1 | Grundturmstück / Base tower section Mât de base / Elemento di torre base Tramo torre base / Peça de base de torre | | | 12,00 | | 2,02 | 2,02 | 3812 |

Klettereinrichtung
Climbing equipment / Equipement de télescopage / Attrezzatura per allungamento della gru
Equipo de trepado / Acessórios p. subida no edifício

| | | | | | | | | | |
|----|---|---|--|--|------|--|------|------|------|
| 13 | 1 | Führungsstück kpl. / Guide section cpl. Cage télescopique cpl. / Gabbia de sopraelevazione compl. Peça de guia compl. / Torre de montagem completa | | | 8,92 | | 2,25 | 2,35 | 2180 |
| 14 | 1 | KUD-Auflagenverlängerung / Slewing ring support extension Rehausse de pivot d'orientation / Prolunga supporto ralla Peça de guia / Prolongación asiento de pista | | | 4,27 | | 2,26 | 2,26 | 1370 |
| 15 | 1 | Hydraulikanlage, Stütz- und Klettertraverse / Hydraulic unit, supporting and climbing cross members Système hydraulique avec traverses d'appui et de télescopage / Sistema idraulico, traversa di appoggio e allungamento gru Instalação hidráulica, travessa de apoio e subida / Sistema hidráulico con traviesa de apoyo y trepado | | | | | | | |

Fundamentkreuz
Cruciform base / Châssis en croix / Carro della gru
Carro de guindaste / Base cruciforme

| | | | | | | | | | |
|----|---|--|--|--|------|--|------|------|------|
| 16 | 1 | Tragholm I / Arm I Longeron I / Longherone I Travessa I / Brazo I | | | 6,66 | | 0,71 | 0,75 | 2110 |
| 17 | 2 | Tragholm II / Arm II Longeron II / Longherone II Travessa II / Brazo II | | | 6,66 | | 0,78 | 0,75 | 2330 |
| 18 | 2 | Fahrschemel mit Antrieb / Rail bogie with drive Bogie moteur / Telaio con gruppo propulsore Quadro sem grupo de propulsão / Caja rodillo motriz | | | 1,07 | | 0,52 | 0,65 | 460 |
| 19 | 2 | Fahrschemel ohne Antrieb / Rail bogie without drive Bogie fou / Telaio senza gruppo propulsore Quadro com grupo de propulsão / Caja rodillo conducido | | | 1,07 | | 0,25 | 0,65 | 380 |
| 20 | 1 | Seile und Kleinteile / Small parts and ropes Accessoire et câbles / Accessori cavi Acessorios e cabos / Accesorios y cables | | | - | | - | - | 4700 |

* Einzelgewichte. / Single weights. / Poids individuels. / Pesì di componenti. / Pesos de peças componentes. / Pesos unitarios.

Klettern im GebäudeClimbing in the building / Télescopage dans le bâtiment / Pure
varianti di gru allungabili / Subida no edifício / Trepado dentro del edificio