

Turmdrehkran 63 LC

Tower Crane / Grue à tour / Gru a torre
Grúa torre / Guindaste de torre

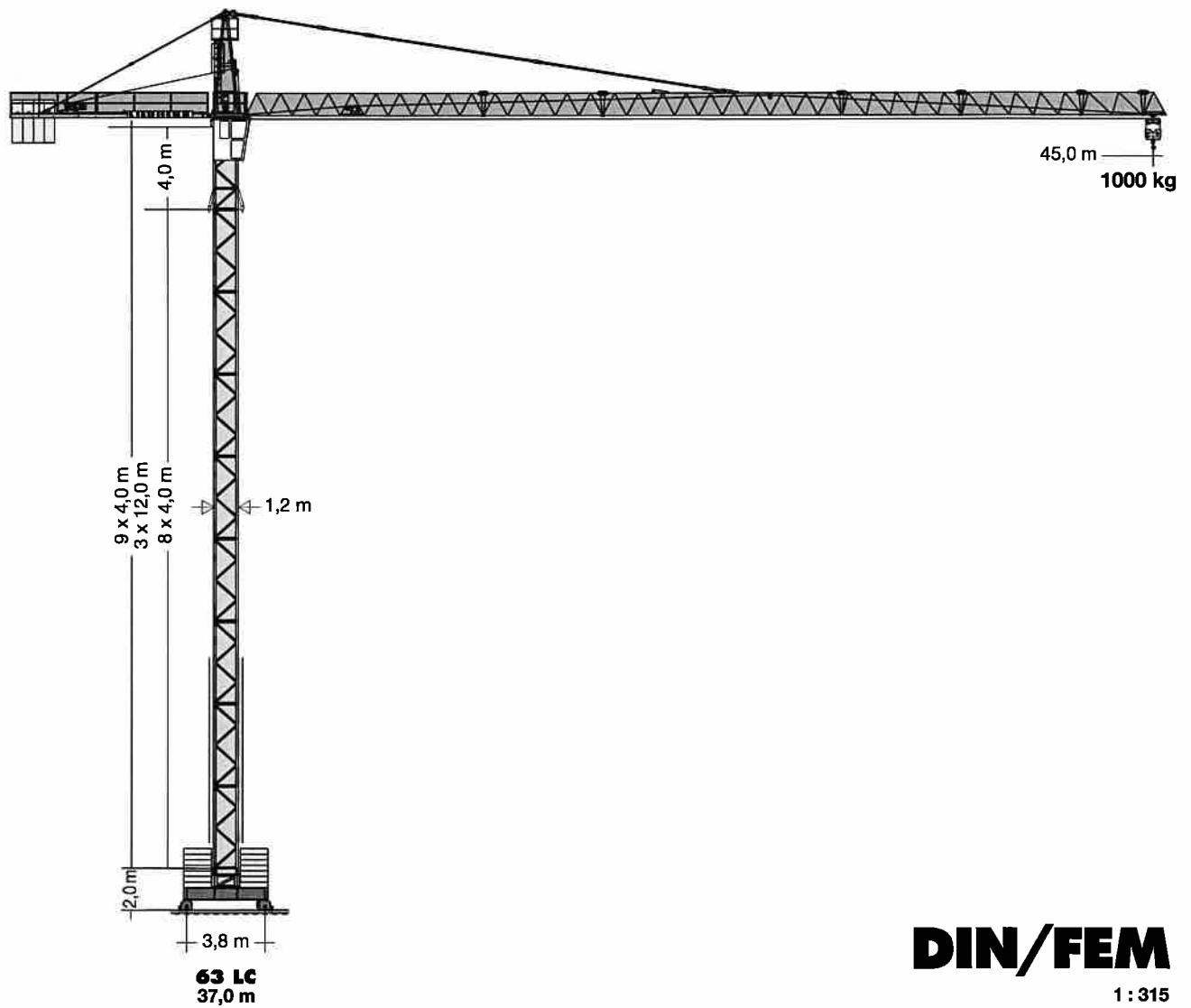

LIEBHERR

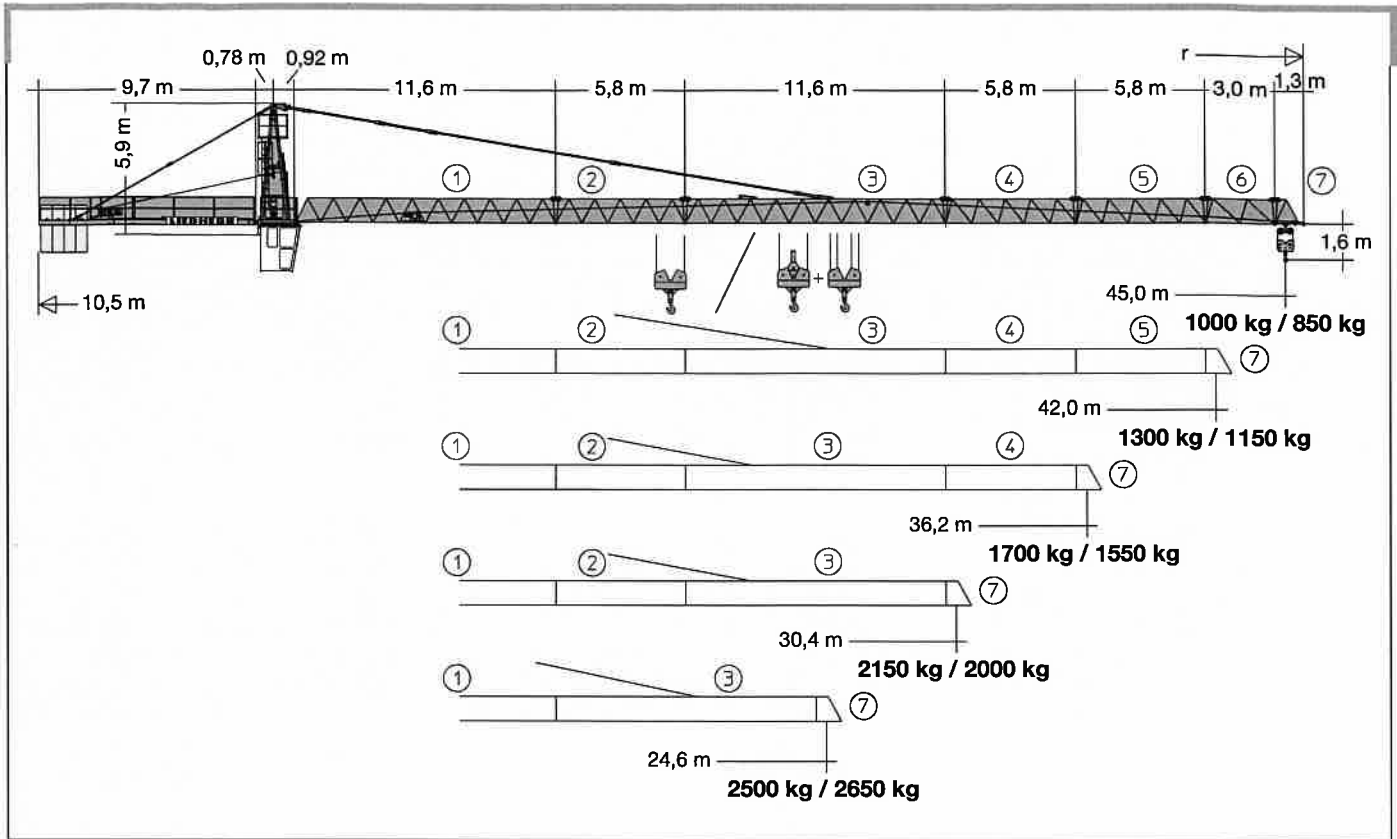

Gewicht

Weight / Poids / Peso / Peso / Pesos

Zentralballast / Central ballast Lest de base / Zavorra centrale Lastro central / Lastre central	FEM: 40000 kg DIN: 50000 kg		(Ausl. 45 m)	9000 kg		19400 kg
--	--------------------------------	---	--------------	---------	---	----------

Hubhöhe

Hoisting height / Hauteur sous crochet / Altezza di sollevamento / Altura bajo gancho / Altura de montagem

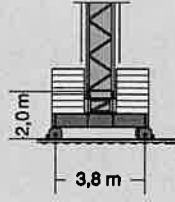
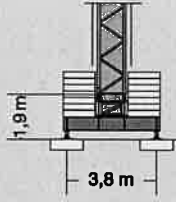
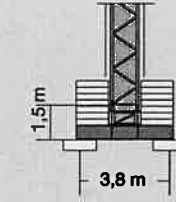
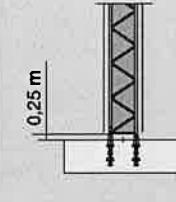
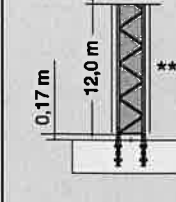
		63 LC				
4 m	12 m					
9*	3	37,0	36,9	36,5	35,3	47,1*
8		33,0	32,9	32,5	31,3	43,1*
7		29,0	28,9	28,5	27,3	39,1
6	2	25,0	24,9	24,5	23,3	35,1
5		21,0	20,9	20,5	19,3	31,1
4		17,0	16,9	16,5	15,3	27,1
3	1	13,0	12,9	12,5	11,3	23,1
2		9,0	8,9	8,5	7,3	19,1
1		5,0	4,9	4,5	3,3	15,1
0						11,1
		m	m	m	m	m
						



* Weitere Hubhöhen auf Anfrage. / Further hoist heights on request. / Hauteurs sous crochet sur demande. / Altre altezze di sollevamento: su richiesta. / Outras alturas de elevação: conforme ao pedido. / Para alturas bajo gancho superiores, consultar.
** nicht kletterbar / not for climbing / non télescopable / non telescopabile / no trepable / no telescopabel







Ausladung und Tragfähigkeit







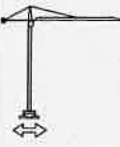











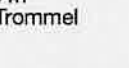



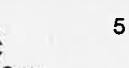











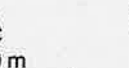











Radius and capacity / Portée et charge / Sbraccio e portata / Alcances y cargas / Alcance e capacidade de carga

m	r	m/kg	m/kg													
			12,0	14,0	16,0	18,0	20,0	22,0	24,6	28,0	30,4	34,0	36,2	40,0	42,0	45,0
45,0	(r = 45,9)	2,1-20,6 2500					2500	2330	2050	1770	1610	1410	1310	1160	1090	1000
42,0	(r = 42,9)	2,1-23,8 2500					2500	2500	2410	2080	1900	1670	1550	1380	1300	
36,2	(r = 37,1)	2,1-25,7 2500					2500	2500	2500	2280	2080	1830	1700			
30,4	(r = 31,3)	2,1-26,6 2500					2500	2500	2500	2360	2150					
24,6	(r = 25,5)	2,1-24,6 2500					2500	2500	2500							

Antriebe







Driving units / Mécanismes d'entraînement / Azionamenti / Mecanismos / Mecanismos

	U/min 0 - 0,8 sl./min tr./min	5,0 kW EDC
	19,0 / 38,0 m/min 21,0 / 42,0 m/min	1,0 / 1,8 kW  1,5 / 3,0 kW 
	20,0 m/min	2 x 2,2 kW
	kVA	 14,0 kW 14,0 kW FU 22,0 kW 26,0 26,0 35,0

		Stufe / Step Cran / Marcia Marcha / Marcha		kg	m/min
	3,2 / 14,0 / 14,0 kW  57,0 m LS-Trommel	4 Lagen Layers Couches Strati Camadas Capas	1 	2500	2500 6,2
			2 	2500	2500 27,0
			3 	1300	1200 54,0
	6 Lagen Layers Couches Strati Camadas Capas	1 	2400	2300 6,5	
		2 	2400	2300 28,5	
		3 	1200	1100 57,0	
	3,8 / 18,5 / 22,0 kW  85,0 m LS-Trommel	3 Lagen Layers Couches Strati Camadas Capas	1 	2500	2500 6,0
			2 	2500	2500 27,0
			3 	1800	1700 56,0
	5 Lagen Layers Couches Strati Camadas Capas	1 	2400	2300 6,5	
		2 	2400	2300 28,5	
		3 	1200	1100 57,0	
	149,0 m LS-Trommel	5 Lagen Layers Couches Strati Camadas Capas	1 	2500	2500 6,2
			2 	2500	2500 28,0
			3 	1700	1600 58,0
	14,0 kW FU  57,0 m LS-Trommel	4 Lagen Layers Couches Strati Camadas Capas	1 	2500	2500 5,0
			2 	2500	2500 25,0
			3 	1900	1800 36,0
	90,0 m LS-Trommel	6 Lagen Layers Couches Strati Camadas Capas	4 	1300	1200 52,0
			1 	5000	2,5
			2 	5000	12,5
	14,0 kW FU  90,0 m LS-Trommel	6 Lagen Layers Couches Strati Camadas Capas	3 	3800	18,0
			4 	2600	26,0
			1 	2500	2500 5,2
	14,0 kW FU  90,0 m LS-Trommel	6 Lagen Layers Couches Strati Camadas Capas	2 	2500	2500 26,0
			3 	1750	1650 37,0
			4 	1200	1100 54,0
	14,0 kW FU  90,0 m LS-Trommel	6 Lagen Layers Couches Strati Camadas Capas	1 	5000	2,6
			2 	5000	13,0
			3 	3500	18,5
	14,0 kW FU  90,0 m LS-Trommel	6 Lagen Layers Couches Strati Camadas Capas	4 	2350	27,0

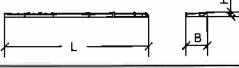
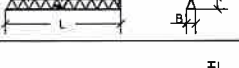
Kranoberteil

Upper part of crane / Partie supérieure de grue / Parte superiore della gru Parte superior grúa / Parte superior do guindaste

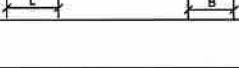
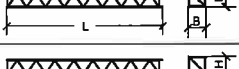
Pos. Item Rep. Voce Pos. Ref.	Anz. Qty. Qta. Cant.				L (m)	B (m)	H (m)	kg*
1	1	Kabine + Steuerstand / Cabin + Seat Cabine + fauteuil / Cabina + poltrona Cabine + cadeira / Cabina + butaca			1,87	1,12	2,18	440
2	1	Turnspitze mit Kud-Auflage Tower head section with slewing ring support Porte-flèche avec pivot / Testa porta-braccio con supporto ralla Cabeça de apoio de lança / Cabeza de torre con asiento de pista			5,57	1,86	1,73	2530
3	1	Gegenausleger / Counter-jib Contre-flèche / Contrabaccio Contra-lança / Contrapluma			9,79	1,46	0,36	960
4	1	Ausleger-Anlenkstück / Jib heel section Pied de flèche / Settore articolato di braccio Base articulada de lança / Pluma tramo primero			11,85	1,04	1,30	⊙ 1070
5	1	Ausleger-Zwischenstück / Intermediate jib section Élément intermédiaire de flèche / Spezzone di braccio Peça suplementar da lança / Tramo intermedio pluma			5,94 11,80 5,94 3,18	0,95 0,95 0,95 0,95	1,22 1,32 1,22 1,22	⊙ 401 ⊙ 810 ⊙ 261 ⊙ 210 ⊙ 111
6	1	Ausleger-Kopfstück / Jib head Pointe de flèche / Punta freccia Cabeça de lança / Tramo punta de pluma			1,45	1,04	1,37	⊙ 80
7	1	Podeste / Platforms Plates-formes / Piattaforma Plataforma / Plataforma			1,90	0,35	1,60	160
8	1	Laufkatze / Trolley Chariot / Carrello Carrinho / Carrito			0,95	1,13	0,62	151
9	1	Unterflasche / Bottom Moufle / Bozzello Gancha / Potipasto			0,75	0,24	0,98	104
10	1	Hubwerk 14 kW / Winch Treuil / Argano / Mecanismo elevatoria Mecanismo elevación carga			1,25	1,23	0,55	450

Turm

Tower / Mât / Torre Torre / Torre

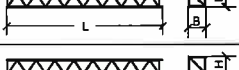
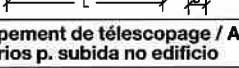
11	1	Turmstück / Tower section Élément de mât / Elemento di torre Torre / Torre		12,0 m 4,0 m	12,27 4,27	1,20 1,20	1,20 1,30	2435 958
12	1	Grundturmstück / Base tower section Mât de base / Elemento di torre base Tramo torre base / Peça de base de torre			12,00	1,42	1,42	3343

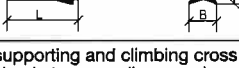
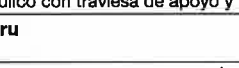

Klettereinrichtung

Climbing equipment / Equipement de télescopage / Attrezzatura per allungamento della gru Equipo de trepado / Acessórios p. subida no edifício

13	1	Führungsstück kpl. / Guide section cpl. Cage télescopique cpl. / Gabbia di sopraelevazione compl. Peça de guia compl. / Torre de montaje completa			8,92	1,65	1,75	1890
14	1	Führungsstück Turmstück / Tower guide section Élément de mât télescopique / Gabbia di sopraelevazione Peça de guia / Tramo torre de montaje			4,27	1,66	1,66	1120
15	1	Hydraulikanlage, Stütz- und Klettertraverse / Hydraulic unit, supporting and climbing cross members Système hydraul. avec traverses d'appui et de télescop. / Sist. idraul., traversa di appoggio e allugam. gru Instalação hidráulica, travessa de apoio e subida / Sistema hidráulico com travessa de apoio y trepado			4,86	0,95	0,70	580

Unterwagen

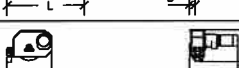
Undercarriage / Châssis / Carro della gru Carro con mástil / Carro de guindaste

16	1	Unterwagen-Rahmen / Undercarriage frame Cadre de châssis / Intelaiatura carro Estrutura do carrinho / Bastidor carretón			4,12	0,94	1,39	2575
17	2	Tragholm / Arm Longeron / Longherone Travessa / Brazo			4,10	0,30	0,60	935
18	2	Fahrschemel mit Antrieb / Rail bogie with drive Bogie moteur / Telaio con gruppo propulsore Quadra sem grupa de propulsão / Caja rodillo motriz			0,78	0,84	0,53	297
19	2	Fahrschemel ohne Antrieb / Rail bogie without drive Bogie fou / Telaio senza gruppo propulsore Quadra com grupa de propulsão / Caja rodillo conducido			0,66	0,30	0,51	204
20	1	Seile und Kleinteile / Small parts and ropes Accessoire et câbles / Accessori cavi Accesorios e cabos / Accesorios y cables			-	-	-	1300

* Einzelgewichte. / Single weights. / Poids individuels. / Pesi di componenti. / Pesos de peças componentes. / Pesos unitarios.

Konstruktionsänderungen vorbehalten!
Subject to alterations! / Sous réserves de modifications!
Si fa riserva di modifiche! / Salvo modificação da construação!
¡Sujeto a modificaciones!

Sämtliche Angaben erfolgen ohne Gewähr. / This information is supplied without liability.
Ces renseignements sont sans garantie. / Le indicazioni contenute si intendono salvo errori ed omissioni.
Declinamos toda responsabilidad derivada de la información proporcionada. / Declinamos qualquer
responsabilidade quanto à informação fornecida.