

**WOLFFKRAN**

Document no.: -

1250B

## Slewing Tower Crane

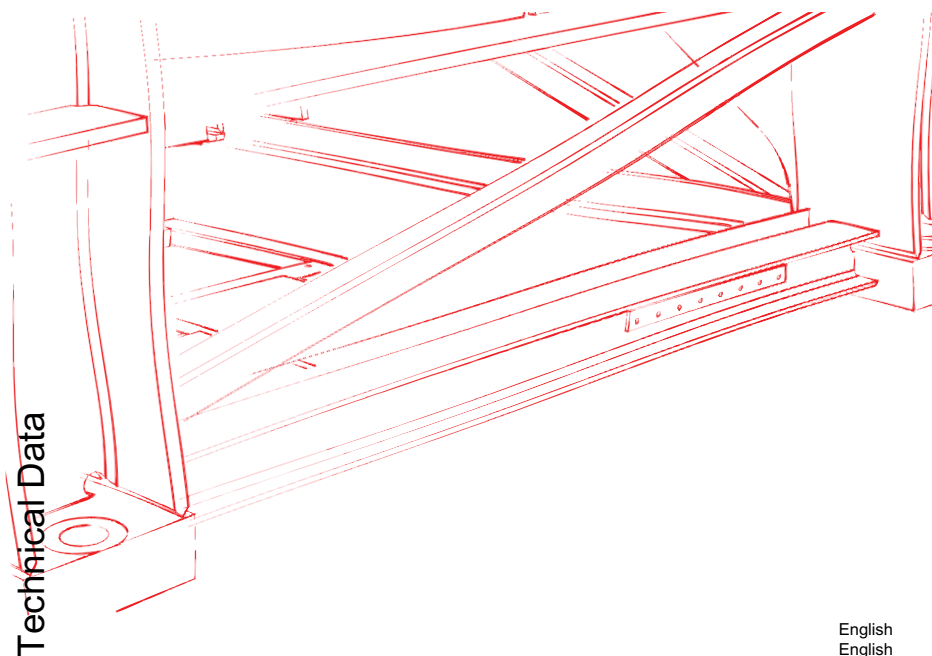

English  
English

WOLFF 1250B

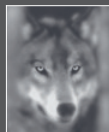

**WOLFFKRAN**

### Imprint

Publisher  
WOLFFKRAN GmbH  
Austraße 72  
74076 Heilbronn  
Germany  
Phone: +49 (0)7131/ 9815-0  
Fax: +49 (0)7131/9815-355  
Web page: <http://www.wolffkran.com>

### Copyright

This documentation including all of its subsections is protected by copyright laws. Any type of use or modification outside of the stringent limits of the copyright laws without permission of WOLFFKRAN GmbH is prohibited and subject to penalties. This applies particularly for copying, translation, microfilming and storage and processing in electronic systems.

Issue date:06/ 2009

## WOLFFKRAN

1	Schedule drawing	5
1.1	Schedule drawing WOLFF 1250 B	5
2	Load carrying capacities	6
2.1	Table of load carrying capacity WOLFF 1250 B (single reeving)	6
2.2	Table of load carrying capacities (kg) in meter intervals, WOLFF 1250 B (single reeving)	7
2.3	Table of load carrying capacity WOLFF 1250 B (double reeving)	8
2.4	Table of load carrying capacities (kg) in meter intervals, WOLFF 1250 B (double reeving)	9
2.5	Load carrying capacity table WOLFF 1250 B (triple reeving)	10
2.6	Table of load carrying capacities (kg) in meter intervals, WOLFF 1250 B (triple reeving)	11
3	Arrangement of counterweight blocks	12
4	Operating speed	13
5	Tower combinations	15
5.1	Tower combinations on foundation (TV33-5 connection)	16
5.2	Tower combinations on cross frame element (TV33-5 connection)	17
5.3	Tower combinations on bogie truck (TV33-5 connection)	18
6	Package list	19
7	Assembly weights	21
7.1	Counterweight blocks	21
7.1.1	Counter weight block 5.97 tons	21
7.1.2	Counter weight block 6.0 tons	22
7.1.3	Counter weight block 8.0 tons	23
7.2	Total weight jib assembly	24
7.3	Assembly weight slewing gear	25
8	Hook height above ground required for mobile cranes	26
9	Assembly diagrams	27
9.1	Jib attachment diagram	27
9.1.1	Jib attachment diagram 80 m to 70 m	28
9.1.2	Jib attachment diagram 65 m to 55 m	29

## WOLFFKRAN

9.1.3	Jib attachment diagram 50 m to 40 m	30
10	Cables	31
10.1	Hoisting rope	31
10.1.1	Casar Eurolift 32mm 1960 N/mm <sup>2</sup>	31
10.2	Luffing cable	33
10.2.1	Casar Turboplast 28 mm 1960 N/mm <sup>2</sup>	33
10.3	Assembly bracing cable	34
10.3.1	Casar Turbolift 36mm 1960 N/mm <sup>2</sup>	34
11	Suitable climbing frames	35
11.1	Outer climbing frames	36
11.1.1	Outer climbing unit KWH 33	37
12	Static data	38
12.1	General- Central ballast weights/ corner loads in compliance with EN 13001/FEM 1.005	38
12.1.1	Foundation loads jib 40-60 m	39
12.1.2	Foundation loads jib 65-70 m	40
12.1.3	Foundation loads jib 75-80 m	41
12.1.4	Slewing section with 40 m Jib on KRE4120	42
12.1.5	Slewing section with 45 m Jib on KRE4120	43
12.1.6	Slewing section with 50 m Jib on KRE4120	44
12.1.7	Slewing section with 55 m Jib on KRE4120	45
12.1.8	Slewing section with 60 m Jib on KRE4120	46
12.1.9	Slewing section with 65 m Jib on KRE4120	47
12.1.10	Slewing section with 70 m Jib on KRE4120	48
12.1.11	Slewing section with 75 m Jib on KRE4120	49
12.1.12	Slewing section with 80 m Jib on KRE4120	50
12.1.13	Slewing section with 40 m Jib on UW4120	51
12.1.14	Slewing section with 45 m Jib on UW4120	52
12.1.15	Slewing section with 50 m Jib on UW4120	53
12.1.16	Slewing section with 55 m Jib on UW4120	54
12.1.17	Slewing section with 60 m Jib on UW4120	55
12.1.18	Slewing section with 65 m Jib on UW4120	56
12.1.19	Slewing section with 70 m Jib on UW4120	57
12.1.20	Slewing section with 75 m Jib on UW4120	58
12.1.21	Slewing section with 80 m Jib on UW4120	59

# WOLFFKRAN

Schedule drawing

## 1 Schedule drawing

### 1.1 Schedule drawing WOLFF 1250 B

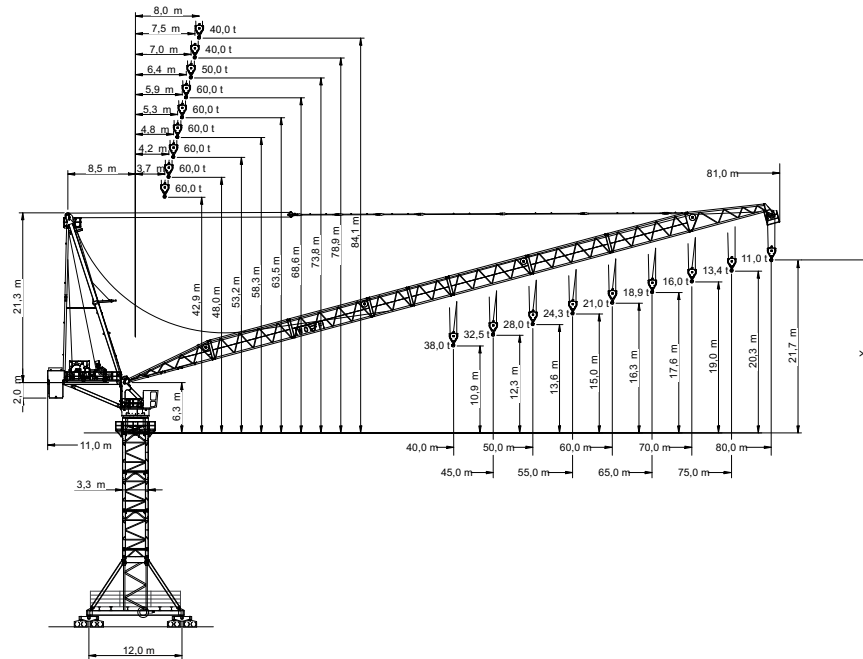

[X] max. hook height above ground

#### Data WOLFF 1250 B

Item	Data
Crane type	BGL GROUP C.0.11.1250
Design	Overhead travelling crane with top slewing trolley jib, with climbing feature
Type of setup	Stationary or travelling
Basis of calculation	EN
Payload torque	max. 15000 kN/m
Hoist winch	Hw 40132FU

# WOLFFKRAN

Load carrying capacities

## 2 Load carrying capacities

### 2.1 Table of load carrying capacity WOLFF 1250 B (single reeving)

 20 t	Operating radius [m]	30	35	40	45	50	55	60	65	70	75	80	LCC	
		Jib length												
JL [m]	80	8.0 - 52.0	20.0	20.0	20.0	20.0	20.0	18.6	16.6	14.9	13.4	12.1	11.0	LCC [t]
	75	7.5 - 55.5	20.0	20.0	20.0	20.0	20.0	20.0	18.1	16.3	14.7	13.4		
	70	7.0 - 59.0	20.0	20.0	20.0	20.0	20.0	20.0	19.6	17.7	16.0			
	65	6.4 - 61.5	20.0	20.0	20.0	20.0	20.0	20.0	20.0	18.9				
	60	5.9 - 60.0	20.0	20.0	20.0	20.0	20.0	20.0	20.0					
	55	5.3 - 55.0	20.0	20.0	20.0	20.0	20.0	20.0						
	50	4.8 - 50.0	20.0	20.0	20.0	20.0	20.0							
	45	4.2 - 45.0	20.0	20.0	20.0	20.0								
	40	3.7 - 40.0	20.0	20.0	20.0									
	JL	Jib length												
LCC	Load carrying capacity													

2.2 Table of load carrying capacities (kg) in meter intervals, WOLFF 1250 B (single reeving)

Operating radius [m]	Jib length [m]			
	65	70	75	80
51	20000	20000	20000	20000
52	20000	20000	20000	20000
53	20000	20000	20000	19510
54	20000	20000	20000	19050
55	20000	20000	20000	18600
56	20000	20000	19770	18160
57	20000	20000	19330	17740
58	20000	20000	18910	17340
59	20000	20000	18490	16950
60	20000	19580	18100	16570
61	20000	19170	17710	16210
62	19840	18770	17340	15850
63	19510	18380	16980	15510
64	19200	18010	16630	15180
65	18900	17650	16290	14860
66		17300	15960	14550
67		16960	15640	14240
68		16630	15330	13950
69		16310	15030	13660
70		16000	14740	13390
71			14460	13120
72			14180	12860
73			13910	12600
74			13650	12360
75			13400	12110
76				11880
77				11650
78				11430
79				11210
80				11000

2.3 Table of load carrying capacity WOLFF 1250 B (double reeving)

JL [m]	Operating radius [m]	30	35	40	45	50	55	60	65	70	75	80	LCC [t]
		80	8.0 - 29.0	38.4	31.9	27.1	23.3	20.2	17.8	15.7	13.9	12.4	
75	7.5 - 30.5	40.0	34.0	29.0	25.0	21.9	19.3	17.1	15.3	13.8	12.4		
70	7.0 - 32.0	40.0	36.1	30.8	26.7	23.4	20.7	18.5	16.6	15.0			
65	6.4 - 33.0	40.0	37.4	32.1	28.0	24.7	22.0	19.8	17.9				
60	5.9 - 34.0	40.0	38.8	33.4	29.3	26.0	23.3	21.0					
55	5.3 - 35.0	40.0	40.0	34.6	30.4	27.1	24.3						
50	4.8 - 36.0	40.0	40.0	35.7	31.4	28.0							
45	4.2 - 37.0	40.0	40.0	36.8	32.5								
40	3.7 - 38.0	40.0	40.0	38.0									
JL		Jib length											
LCC		Load carrying capacity											

2.4 Table of load carrying capacities (kg) in meter intervals, WOLFF 1250 B (double reeving)

Operating radius [m]	Jib length [m]								
	40	45	50	55	60	65	70	75	80
28	40000	40000	40000	40000	40000	40000	40000	40000	40000
29	40000	40000	40000	40000	40000	40000	40000	40000	40000
30	40000	40000	40000	40000	40000	40000	40000	40000	38430
31	40000	40000	40000	40000	40000	40000	40000	39250	36960
32	40000	40000	40000	40000	40000	40000	40000	37820	35590
33	40000	40000	40000	40000	40000	40000	38600	36480	34300
34	40000	40000	40000	40000	40000	38680	37290	35210	33080
35	40000	40000	40000	40000	38750	37430	36050	34020	31930
36	40000	40000	40000	38800	37560	36260	34880	32890	30850
37	40000	40000	38840	37670	36440	35150	33780	31830	29830
38	40000	38890	37740	36590	35380	34090	32730	30820	28850
39	38970	37840	36700	35570	34380	33090	31730	29860	27930
40	38000	36840	35710	34600	33420	32140	30790	28950	27060
41		35880	34770	33680	32510	31240	29890	28090	26230
42		34980	33880	32800	31650	30380	29040	27260	25430
43		34110	33020	31970	30820	29560	28220	26480	24680
44		33290	32210	31170	30030	28780	27440	25730	23960
45		32500	31430	30410	29280	28030	26700	25010	23270
46			30680	29680	28560	27310	25980	24330	22610
47			29970	28980	27870	26630	25300	23670	21980
48			29290	28310	27210	25970	24650	23040	21370
49			28630	27660	26580	25340	24020	22440	20790
50			28000	27050	25970	24740	23420	21860	20240
51				26450	25380	24160	22840	21300	19700
52				25890	24820	23600	22290	20770	19190
53				25340	24280	23060	21750	20250	18690
54				24810	23760	22540	21240	19760	18210
55				24300	23260	22040	20740	19280	17750
56					22770	21560	20260	18820	17310
57					22310	21100	19800	18370	16880
58					21860	20650	19360	17940	16470
59					21420	20220	18930	17530	16070
60					21000	19800	18510	17130	15690
61						19390	18110	16740	15310
62						19000	17720	16370	14950
63						18620	17340	16000	14600
64						18260	16970	15650	14260
65						17900	16620	15310	13940
66							16280	14980	13620
67							15940	14660	13310
68							15620	14350	13010
69							15310	14040	12720
70							15000	13750	12440
71								13470	12160
72								13190	11900
73								12920	11640
74								12660	11380
75								12400	11140
76									10900
77									10660
78									10440
79									10220
80									10000

2.5 Load carrying capacity table WOLFF 1250 B (triple reeving)

JL [m]	Operating radius [m]	60 t	Jib length [m]												LCC [t]
			30	35	40	45	50	55	60	65	70	75	80		
70	7.0 - 26.0	50.0 t	42.4	35.3	30.0	25.8	22.5	19.8	17.6	15.6	14.0				LCC [t]
	6.4 - 22.5	60.0 t	43.5	36.5	31.2	27.0	23.8	21.1	18.8	16.9					
	5.9 - 23.0		44.9	37.8	32.4	28.3	25.0	22.3	20.0						
	5.3 - 23.5		46.1	39.0	33.6	29.4	26.0	23.3							
	4.8 - 24.0		47.3	40.1	34.6	30.4	27.0								
	4.2 - 24.5		48.5	41.2	35.8	31.5									
40	3.7 - 25.0		49.8	42.5	37.0										
JL	Jib length														
LCC	Load carrying capacity														

2.6 Table of load carrying capacities (kg) in meter intervals, WOLFF 1250 B (triple reeving)

Operating radius [m]	Jib length [m]									
	40	45	50	55	60	65	70	75	80	
20	60000	60000	60000	60000	60000	60000	50000	-	-	
21	60000	60000	60000	60000	60000	60000	50000	-	-	
22	60000	60000	60000	60000	60000	60000	50000	-	-	
23	60000	60000	60000	60000	60000	58570	50000	-	-	
24	60000	60000	60000	58670	57300	55880	50000	-	-	
25	60000	58750	57460	56160	54810	53410	50000	-	-	
26	57640	56390	55120	53840	52520	51130	50000	-	-	
27	55460	54210	52950	51690	50390	49010	47880	-	-	
28	53430	52180	50930	49700	48420	47050	45910	-	-	
29	51540	50290	49060	47850	46580	45230	44080	-	-	
30	49780	48530	47310	46120	44860	43520	42360	-	-	
31	48130	46880	45670	44500	43260	41930	40760	-	-	
32	46580	45340	44130	42980	41760	40430	39260	-	-	
33	45130	43890	42690	41550	40340	39030	37850	-	-	
34	43760	42520	41330	40210	39010	37700	36520	-	-	
35	42480	41230	40050	38950	37760	36460	35270	-	-	
36	41260	40020	38850	37750	36580	35280	34090	-	-	
37	40110	38860	37700	36620	35460	34170	32970	-	-	
38	39020	37770	36620	35550	34400	33110	31910	-	-	
39	37980	36740	35590	34530	33390	32110	30910	-	-	
40	37000	35760	34620	33570	32430	31160	29950	-	-	
41		34820	33690	32650	31520	30260	29050	-	-	
42		33930	32800	31770	30660	29400	28180	-	-	
43		33080	31960	30940	29830	28570	27360	-	-	
44		32270	31150	30140	29040	27790	26570	-	-	
45		31500	30380	29380	28290	27040	25820	-	-	
46			29650	28660	27570	26320	25100	-	-	
47			28940	27960	26880	25640	24410	-	-	
48			28270	27290	26220	24980	23750	-	-	
49			27620	26650	25580	24350	23120	-	-	
50				27000	26040	24970	23750	22510	-	-
51					25450	24390	23160	21930	-	-
52					24880	23830	22600	21360	-	-
53					24330	23280	22070	20820	-	-
54					23810	22760	21550	20300	-	-
55					23300	22260	21050	19800	-	-
56						21780	20570	19320	-	-
57						21310	20100	18850	-	-
58						20860	19650	18400	-	-
59						20420	19220	17970	-	-
60						20000	18800	17550	-	-
61							18400	17140	-	-
62							18000	16740	-	-
63							17620	16360	-	-
64							17260	15990	-	-
65							16900	15640	-	-
66								15290	-	-
67								14950	-	-
68								14630	-	-
69								14310	-	-
70								14000	-	-
71								-	-	-
72								-	-	-

3 Arrangement of counterweight blocks

Jib length [m]	80	75	70	65	60	55	50	45	40								
Total weight 75.76 t																	
																	8 x 5.97 tons suspended steel weight
																	2 x 8 tons suspended concrete weight
										2 x 6 tons lying concrete weight							

4 Operating speed

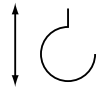
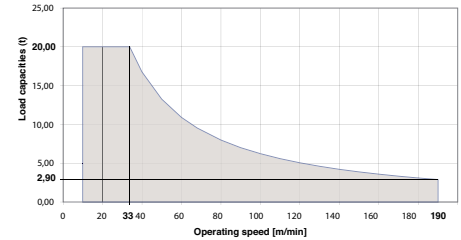
Drive unit [type]	Operating speed Carrying load		Hook travel distance max. [m]	Power [kW]	Total connected wattage [kVA]
Hw40132FU	Lifting / lowering		990	132	194.0 Total connected wattage at simultaneity factor 0.7
					
Tower height max [m] (with jib length of 80 m)					905

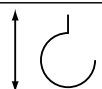
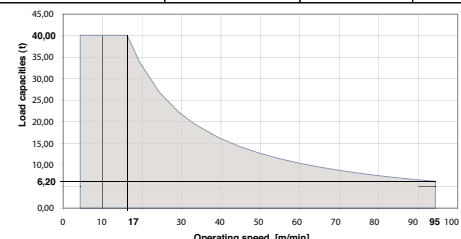
Drive unit [type]	Operating speed Carrying load		Hook travel distance max. [m]	Power [kW]	Total connected wattage [kVA]
Hw40132FU	Lifting / lowering		495	132	194.0 Total connected wattage at simultaneity factor 0.7
					
Tower height max [m] (with jib length of 80 m)					410

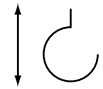
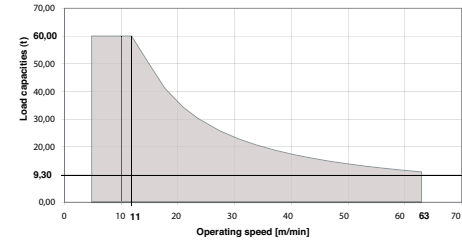
Drive unit [type]	Operating speed Carrying load		Hook travel distance max. [m]	Power [kW]	Total connected wattage [kVA]
Hw40132FU	Lifting / lowering		330	132	194.0 Total connected wattage at simultaneity factor 0.7
					
Tower height max [m] (with jib length of 80 m)					245

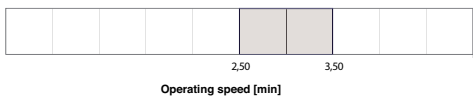
Drive unit [type]	Operating speed		Power [kW]	Total connected wattage [kVA]
EW 16110FU	Jib luffing in / out		110	194.0 Total connected wattage at simultaneity factor 0.7
				

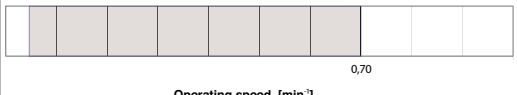
Drive unit [type]	Operating speed		Power [kW]	Total connected wattage [kVA]
SG	Slewing		2 x 11	194.0 Total connected wattage at simultaneity factor 0.7
				

5 Tower combinations



**DANGER**

Usage of wrong tower combinations

The slewing tower crane may overturn.

- 1) Use the specified tower combinations.
- 2) Do you need a different tower combination contact the WOLFFKRAN GmbH and get an alternative tower combination confirmed in writing.



**NOTICE**

All tower combinations apply to free standing slewing tower cranes without climbing gear.

5.1 Tower combinations on foundation (TV33-5 connection)

Jib length		40 to 60 m	65 to 70 m	75 to 80 m
Elements				
1	5.0 m	TV 33-5	TV 33-5	TV 33-5
2	10.0 m	TV 33-5	TV 33-5	TV 33-5
3	15.0 m	TV 33-5	TV 33-5	TV 33-5
4	20.0 m	TV 33-5	TV 33-5	TV 33-5
5	25.0 m	TV 33-5	TV 33-5	TV 33-5
6	30.0 m	TV 33-5	TV 33-5	TV 33-5
7	35.0 m	TV 33-5	TV 33-5	TV 33-5
8	40.0 m	TV 33-5	TV 33-5	TV 33-5
9	45.0 m	TV 33-5	TV 33-5	TV 33-5
10	50.0 m	TV 33-5	TV 33-5	TV 33-5
11	55.0 m	TV 33-5	TV 33-5	TV 33-5
12	60.0 m	TV 33-5	TV 33-5	TV 33-5
13	65.0 m	TV 33-5	TV 33-5	TV 33-5
14	70.0 m	TV 33-5	TV 33-5	TV 33-5
15	75.0 m	TV 33-5	TV 33-5	TV 33-5
16	80.0 m	TV 33-5	TV 33-5	TV 33-5
17	85.0 m	TV 33-5	TV 33-5	
18	90.0 m	TV 33-5		
Foundation		FUA G	FUA G	FUA G
Tower height [m]		90.0	85.0	80.0



5.2 Tower combinations on cross frame element (TV33-5 connection)

Jib length	40 to 55 m	60 to 70 m	75 to 80 m
Element			
1	5.0 m	TV 33-5	TV 33-5
2	10.0 m	TV 33-5	TV 33-5
3	15.0 m	TV 33-5	TV 33-5
4	20.0 m	TV 33-5	TV 33-5
5	25.0 m	TV 33-5	TV 33-5
6	30.0 m	TV 33-5	TV 33-5
7	35.0 m	TV 33-5	TV 33-5
8	40.0 m	TV 33-5	TV 33-5
9	45.0 m	TV 33-5	TV 33-5
10	50.0 m	TV 33-5	TV 33-5
11	55.0 m	TV 33-5	TV 33-5
12	60.0 m	TV 33-5	TV 33-5
13	65.0 m	TV 33-5	TV 33-5
14	70.0 m	TV 33-5	TV 33-5
15	75.0 m	TV 33-5	TV 33-5
16	80.0 m	TV 33-5	
Substructure	KRE 4120	KRE 4120	KRE 4120
[m x m]	12.0 X 12.0	12.0 X 12.0	12.0 X 12.0
Substructure height [m]	8.7	8.7	8.7
Tower height [m]	88.7	83.7	78.7







5.3 Tower combinations on bogie truck (TV33-5 connection)

Jib length	40 to 55 m	60 to 70 m	75 to 80 m
Element			
1	5.0 m	TV 33-5	TV 33-5
2	10.0 m	TV 33-5	TV 33-5
3	15.0 m	TV 33-5	TV 33-5
4	20.0 m	TV 33-5	TV 33-5
5	25.0 m	TV 33-5	TV 33-5
6	30.0 m	TV 33-5	TV 33-5
7	35.0 m	TV 33-5	TV 33-5
8	40.0 m	TV 33-5	TV 33-5
9	45.0 m	TV 33-5	TV 33-5
10	50.0 m	TV 33-5	TV 33-5
11	55.0 m	TV 33-5	TV 33-5
12	60.0 m	TV 33-5	TV 33-5
13	65.0 m	TV 33-5	
Substructure	UW 4120	UW 4120	UW 4120
[m x m]	12.0 X 12.0	12.0 X 12.0	12.0 X 12.0
Substructure height [m]	10.0	10.0	10.0
Tower height [m]	75.0	70.0	65.0

# WOLFFKRAN

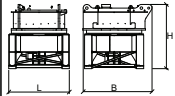
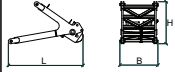

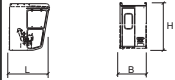
Package list

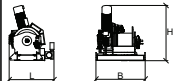
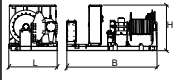
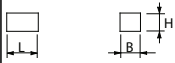
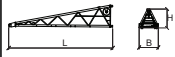
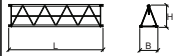
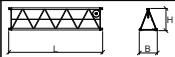
## 6 Package list

Quantity	Description	Package	L (m)	W (m)	H (m)	Weight (kg)	Volume (m <sup>3</sup> )
1	Tower top with roll block and pedestals		11.90	2.50	2.82	13100	83.90
1	Tower top stays		10.48	0.99	0.49	2900	5.08
1	Tower head bottom		3.33	3.79	3.53	23700	44.55
1	Connecting block with ladder		4.98	2.54	2.80	7300	35.41
1	Operator cabin suspension		3.58	2.23	0.56	560	4.47
1	Operator cabin		1.90	1.44	2.34	750	6.40
1	Counterjib with struts and pedestals		9.81	2.50	1.25	8500	30.66
1	Machine platform with boom hoist, 2 brake		2.03	2.23	2.50	6200	11.32
1	Machine platform with hoist gear, 2 brake (incl. 1000 m Ø 32 mm hoisting rope = 5 tons)		2.60	4.85	2.39	17500	30.14
1	Box (small parts)		0.63	0.50	0.38	100	1.12
	Standard railings		2.60	1.10	0.65	300	1.86
1	Jib element 1 (without pedestals)		11.89	2.55	2.51	4400	76.10
1	Jib element 2		10.59	2.03	2.50	3100	53.74
1	Jib element 3		10.59	2.03	2.50	3200	53.74

# WOLFFKRAN

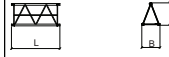
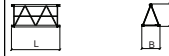
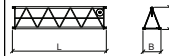
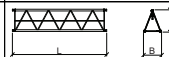
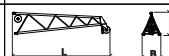
Package list

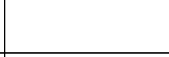
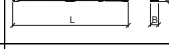
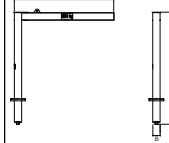
1	Jib element 4		5.41	2.03	2.50	1600	27.46
1	Jib element 5		5.41	2.03	2.50	1600	27.46
1	Jib element 6		10.59	2.03	2.50	2600	53.74
2	Jib element 7		10.59	2.03	2.50	2500	53.74
1	Jib element 8 (without pedestals)		11.13	2.03	2.52	3800	56.94
	Hook block (single reeving)		1.08	0.34	1.99	600	0.73
	Hook block (double reeving)		1.20	0.40	1.99	1000	0.96
	Hook block, triple reeving		1.20	0.50	1.99	1500	1.20
1	Stay rods for 80 m operating radius		10.58	0.74	0.27	3200	2.11
1	Auxiliary crane		2.53	2.96	0.30	218	2.25

Package list 1250 B

# WOLFFKRAN

## Assembly weights

### 7 Assembly weights

#### 7.1 Counterweight blocks

##### 7.1.1 Counter weight block 5.97 tons

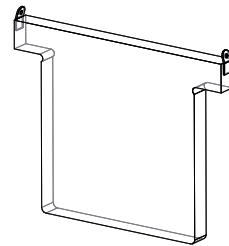
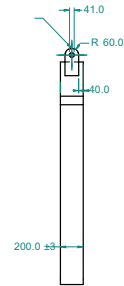
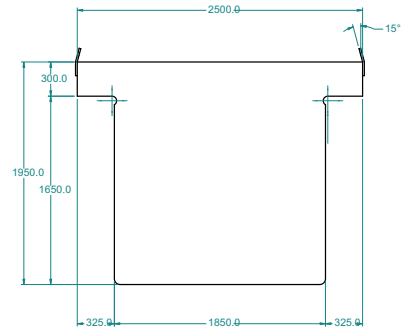

Item	Data
Material	Material quality S235JR, max. carbon content 0.25%
Max. permitted weight tolerance	+/- 2 %
Order number	30046411

# WOLFFKRAN

## Assembly weights

### 7.1.2 Counter weight block 6.0 tons

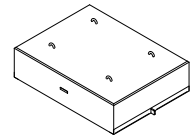
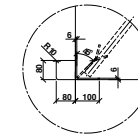
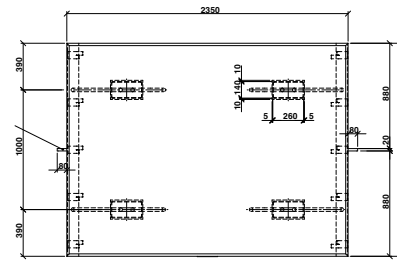
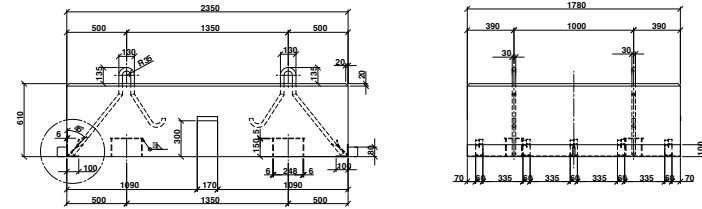

Item	Data
Material	Concrete, min. B 25 Density = 2.35 t / m <sup>3</sup>
Max. permitted weight tolerance	+/- 2 %
Order number	30047367

# WOLFFKRAN

Assembly weights

## 7.1.3 Counter weight block 8.0 tons

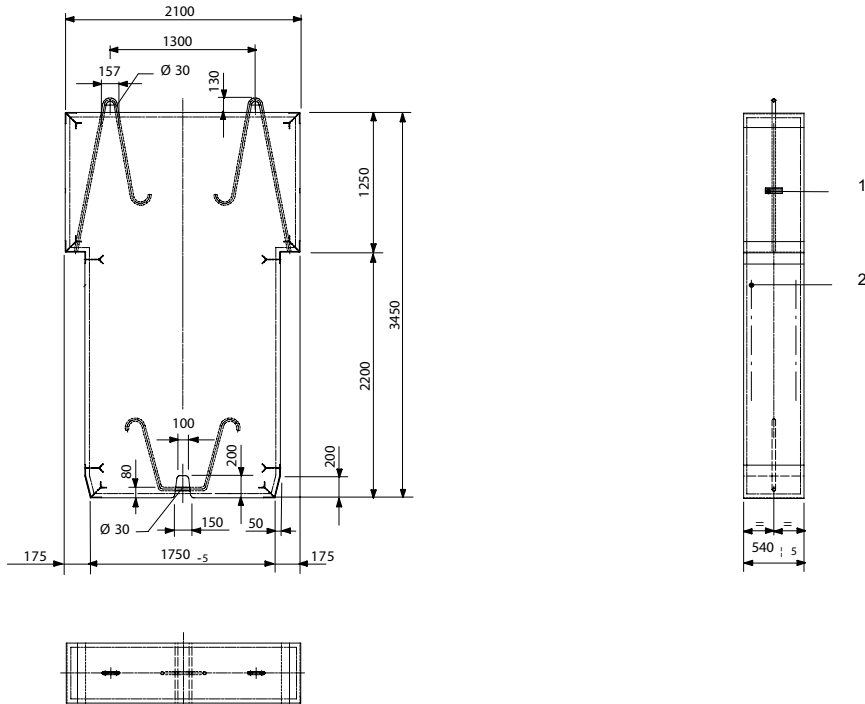

Item	Data
Material	Concrete, min. B 25 Density = 2.35 t / m <sup>3</sup>
Max. permitted weight tolerance	+/- 2 %
Order number	30043944
1	Component identifier
2	Structural steel reinforcement

# WOLFFKRAN

Assembly weights

## 7.2 Total weight jib assembly

Complete jib: mechanical parts, stay brackets, bucks, assembly stay ropes, assembly rope pulleys, hook block

Jib length [m]	Weight (kg) WOLFF 1250 B
80.0	29800
75.0	27900
70.0	26700
65.0	24800
60.0	23600
55.0	21700
50.0	20400
45.0	18500
40.0	16600

## WOLFFKRAN

Assembly weights

### 7.3 Assembly weight slewing gear

Module	Crane parts	Weight (kg)	
Tower top			15940
	■ Tower head top (including struts, pedestals and standard railing)	15420	
	■ Roll block	350	
	■ Shock absorber	170	
Tower head bottom			23700
	■ SPUT	14015	
	■ Slewing frame + KDV	9670	
Counterjib (including struts, pedestals and standard railing)			8780
Machine platform hoisting gear (1000 m rope = 5 to)			17500
Machine platform boom hoist			6200

## WOLFFKRAN

Hook height above ground required for mobile cranes

### 8 Hook height above ground required for mobile cranes

For information about the height of the WOLFF slewing tower crane, refer to Tower combinations [15].

**NOTICE!** Allowances must be made during assembly for level differences (mobile crane to base of the slewing tower crane).

Hook height above ground required for mobile cranes (X) = height of the WOLFF slewing tower crane (A) + clearance of 30 (B).

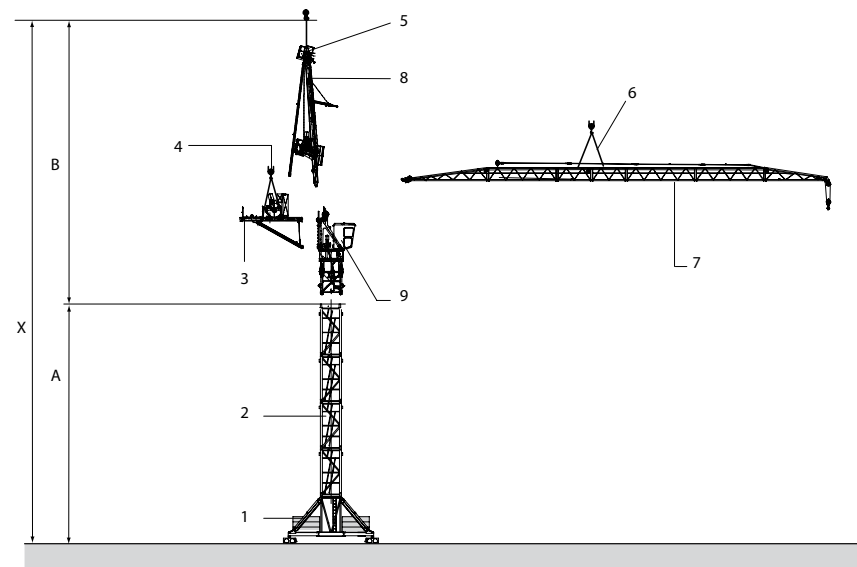

Exemplary illustration

[A]	Height of the WOLFF slewing tower crane	[B]	Clearance 30 m
[X]	Hook height above ground required for the mobile crane		
1	Bogie truck	5	Single sling (2m with shackle)
2	Tower element	6	Two-fall attachment with shackle
3	Counterjib, complete	7	Jib, complete
4	Four-fall attachment (with shackle)	8	Cat head, complete

(see also):

- Tower combinations [15]

# WOLFFKRAN

Assembly diagrams

## 9 Assembly diagrams

### 9.1 Jib attachment diagram



**NOTICE**

Use a double suspension tackle of at least 6 m length for jib assembly.



**NOTICE**

To install the hook block within two sling ropes to DIN 3088 (Ø 8 mm x 1 m with shackle), attach it to the trolley, reeve in the mounting rope (Perlon, Ø 14 mm x 12 m) and secure it on the trolley.

#### Length of jib elements

Item	in [m]
Jib element 1	11.60
Jib element 2, 3, 6, 7	10.35
Jib element 4, 5	5.18
Jib element 8	10.35

# WOLFFKRAN

Assembly diagrams

### 9.1.1 Jib attachment diagram 80 m to 70 m

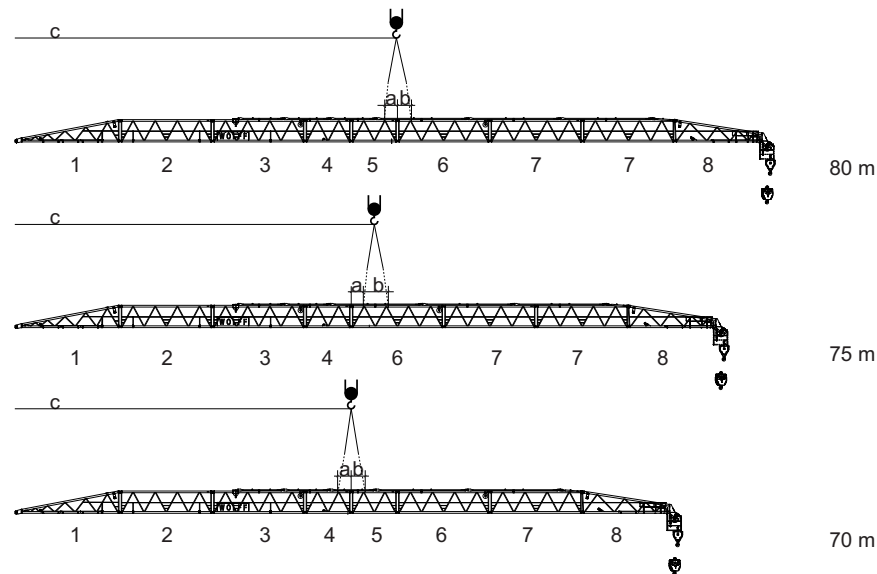

Data	Jib length [m]		
	80	75	70
a [m]	1.55	1.30	1.55
b [m]	1.60	2.78	1.55
c [m]	42.70	40.20	37.50
Weight (kg)	29800	27900	26700

# WOLFFKRAN

Assembly diagrams

## 9.1.2 Jib attachment diagram 65 m to 55 m

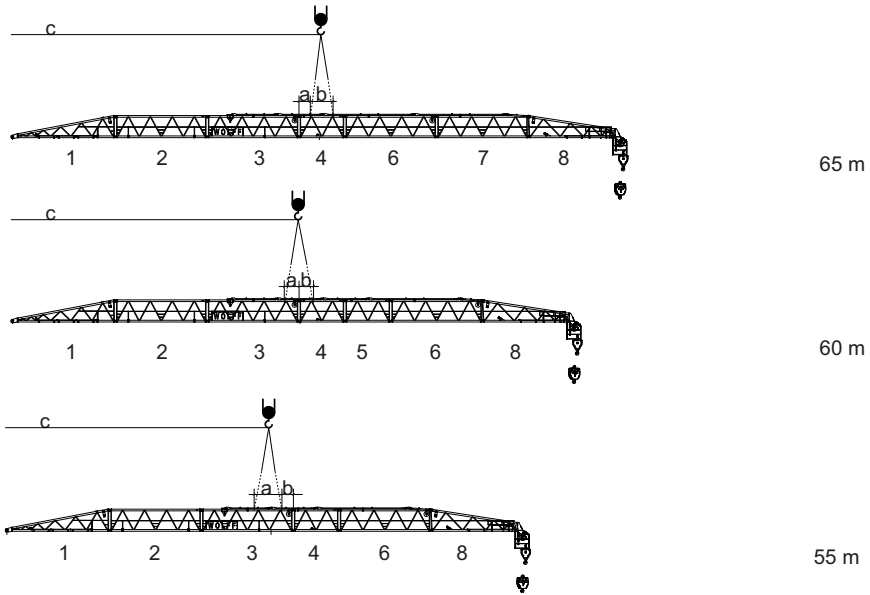

Data	Jib length [m]		
	65	60	55
a [m]	1.25	1.60	2.78
b [m]	2.67	1.55	1.30
c [m]	34.90	32.30	29.60
Weight (kg)	24800	23600	21700

# WOLFFKRAN

Assembly diagrams

## 9.1.3 Jib attachment diagram 50 m to 40 m

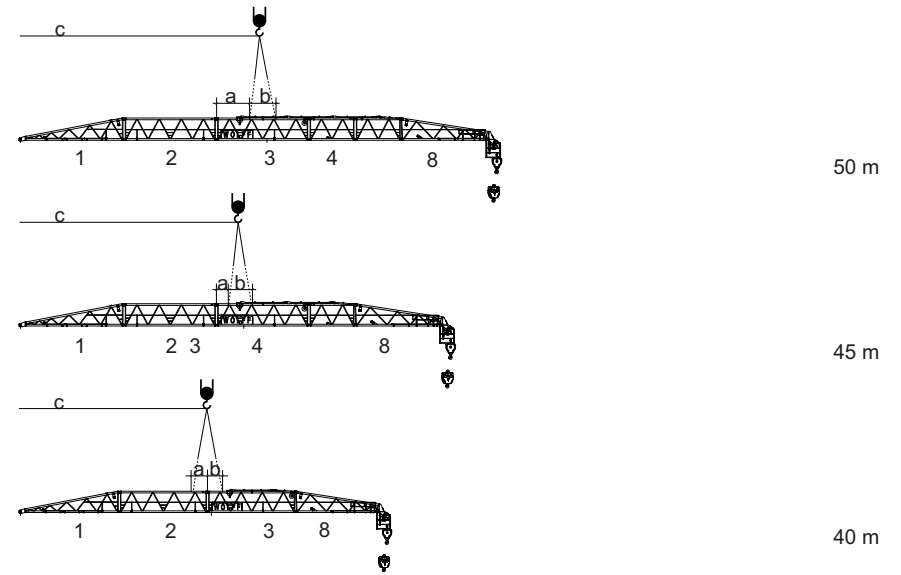

Data	Jib length [m]		
	50	45	40
a [m]	3.78	1.30	1.60
b [m]	2.78	2.78	1.60
c [m]	27.10	24.60	22.00
Weight (kg)	20400	18500	16600

## WOLFFKRAN

Cables

### 10 Cables

#### 10.1 Hoisting rope

##### 10.1.1 Casar Eurolift 32mm 1960 N/mm<sup>2</sup>

#### Cable diameter: 32 mm

- +2% + 4%
- According to DIN 15020 standard
- To be used according to TWG 1 Am

#### Original equipment

- CASAR EUROLIFT
- Non-twisting, flexible hoisting cable with compacted outer strands and compacted steel cable core.

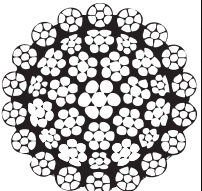
	Item	Data
	Rated strength	= 1960 N/ mm <sup>2</sup>
	Calculated breaking force	1135.5 kN
	Minimum breaking force	930.0 kN
	Weight per meter	5.040 kg

#### Type of cable

Right-hand long-lay type consisting of bare steel wire strands.

Item	Data
Mean space factor	= 0.72
Mean stranding factor	= 0.82
Mean weight factor	= 0.87
Mean total number of wires	= 280
Number of supporting wires in outer strands for evaluation of wear limit, according to DIN 15020, sheet 2/ ISO DIS 4309	= 126

#### Basic equipment

Cable length	Layout
■ 400 m	<ul style="list-style-type: none"><li>■ Rope fall: double</li><li>■ Jib radius: 80 m</li><li>■ Tower height: 40.0 m</li></ul>

## WOLFFKRAN

Cables



#### NOTICE

When the hook travel is increased by 1 tower element (5.0 m), the required cable length increases by 5 m for a single cable fall, by 10 m for a dual cable fall and by 15 m for a threefold cable fall.



## WOLFFKRAN

Cables

### 10.2 Luffing cable

#### 10.2.1 Casar Turboplast 28 mm 1960 N/mm<sup>2</sup>

##### Cable diameter: 28 mm

- +2% + 4%
- According to DIN 15020 standard
- To be used according to TWG 1 Am

##### Original equipment

- CASAR TURBOPLAST
- 8 - strand rope made out of compacted outer strands

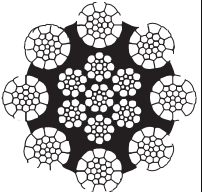
	Item	Data
	Rated strength	= 1960 N/ mm <sup>2</sup>
	Calculated breaking force	794.2 kN
	Minimum breaking force	697.3 kN
	Weight per meter	3.525 kg

##### Type of cable

- Right-hand long-lay type, left-handed.
- bare stranding wires

Item	Data
Mean space factor	= 0.665
Mean stranding factor	= 0.85
Mean weight factor	= 0.87
Mean total number of wires	= 327
Number of supporting wires in outer strands for evaluation of wear limit according to DIN 15020, sheet 2/ ISO DIS 4309	= 208

##### Basic equipment

Cable length	Layout
■ 1 x 310 m	■ Layout: 40 - 80 m

## WOLFFKRAN

Cables

### 10.3 Assembly bracing cable

#### 10.3.1 Casar Turbolift 36mm 1960 N/mm<sup>2</sup>

##### Cable diameter: 36 mm

- +2% + 4%
- According to DIN 15020 standard
- To be used according to TWG 1 Am

##### Original equipment

- CASAR TURBOLIFT
- an 8 - strand rope in parallel lay construction made out of compacted strands

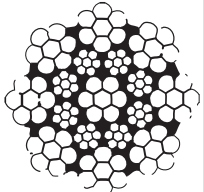
	Item	Data
	Rated strength	= 1960 N/ mm <sup>2</sup>
	Calculated breaking force	1465.0 kN
	Minimum breaking force	1220.0 kN
	Weight per meter	6.278 kg

##### Type of cable

- Right-hand cross-lay version
- Strand surfaces: Galvanized

Item	Data
Mean space factor	= 0.734
Mean stranding factor	= 0.83
Mean weight factor	= 0.84
Mean total number of wires	= 311
Number of supporting wires in outer strands for evaluation of wear limit according to DIN 15020, sheet 2/ ISO DIS 4309	= 208

##### Basic equipment

Cable length	Layout
■ 2 x 43.9 m	■ Layout: 40 - 80 m

## 11 Suitable climbing frames

This section contains information on

- Outer climbing frames
- Inner climbing frames (KSH)

**WARNING**

Climbing unit attached to the cat head bottom section  
Increased wind surface. Slewing tower crane collapse.

- 1) Lower the climbing unit down on the tower, or
- 2) dismantle the climbing unit.

**NOTICE**

Clamping forces for the inner climbing frame (KSH) are specified based on a building height of < 250m and wind region C 25

**NOTICE**

The operating radius specified is measured from the tower center and is to be considered a reference value. The unit can be balanced precisely by moving the trolley either with the tower element specified in the table, or under load.

**NOTICE**

The data required and the instructions for tower assemblies with inner climbing frame is available in the separate description of the inner climbing frame.

**DANGER!** Observe the special tower combination for the inner climbing frame.

## 11.1 Outer climbing frames

**NOTICE**

If feasible, you should preferably operate your climbing frame without balancing weight.

11.1.1 Outer climbing unit KWH 33

NOTICE

Minimum height for stationary setup:  
3 tower elements (15 m tower height) + Climbing tower piece

Minimum height for crawling towers:  
3 tower elements (15 m tower height) + Climbing tower piece + bogie truck

Climbing radius for the balancing weights

1250 B	Jib length [m]								
	80	75	70	65	60	55	50	45	40
no weight	64.9	68.0	-	-	-	-	-	-	-
Weight = 5.00 t	-	-	50.7	52.6	53.6	-	-	-	-
TV 33 = 9.45 t	-	-	-	-	-	44.6	45.2	-	-
Weight = 15.00 t	-	-	-	-	-	-	-	38.2	-
Weight = 17.00 t	-	-	-	-	-	-	-	-	36.6

12 Static data

12.1 General- Central ballast weights/ corner loads in compliance with EN 13001/FEM 1.005

**Jib positions**

The corner loads are given for two jib positions with the maximum corner load resulting from jib position 1.

For square setup, the following equation is true:  $a = b$

For rectangular setup, the following equation is true:  $a > b$

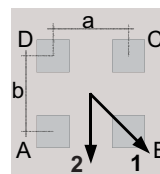

Cross frame or cross frame element

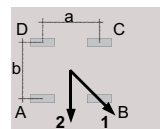

bogie truck

**NOTICE!** For undercarriage details, please refer to the relevant operating manual.

**Wind load with crane out of operation** *Windbelastung ausser Betrieb*

The stability for stormy weather is calculated on the basis of wind region C (EN 13001-2). The reference wind speed for zone C is 28 m/s (10 m above ground, averaged over 10 minutes). As a basis, a recurrence interval of 25 years is used.

# WOLFFKRAN

Static data

## 12.1.1 Foundation loads jib 40-60 m

Slewing section with 40-60 m jib on foundation

Slewing tower crane without climbing frame

TH	Crane in service			Crane out of service			Assembly		
	Slewing torque: 750 kNm			Wind region C25					
	M	V	H	M	V	H	M	V	H
[m]	[kNm]	[kN]	[kN]	[kNm]	[kN]	[kN]	[kNm]	[kN]	[kN]
5.0	12280	2155	43	9090	1936	110	5070	1161	17
10.0	12520	2254	47	9690	2035	124	5160	1260	19
15.0	12790	2353	51	10360	2134	137	5260	1359	21
20.0	13100	2452	55	11110	2233	151	5380	1458	24
25.0	13440	2551	59	11940	2332	164	5520	1557	26
30.0	13820	2650	64	12850	2431	177	5670	1656	28
35.0	14240	2749	68	13850	2530	190	5840	1755	31
40.0	14710	2848	72	14930	2629	204	6020	1854	33
45.0	15210	2947	76	16110	2728	217	6220	1953	35
50.0	15760	3046	80	17390	2827	230	6440	2052	38
55.0	16370	3145	84	18770	2926	243	6680	2151	40
60.0	17020	3244	88	20260	3025	257	6940	2250	42
65.0	17730	3343	93	21860	3124	270	7220	2349	45
70.0	18510	3442	97	23590	3223	283	7520	2448	47
75.0	19350	3541	101	25450	3322	296	7850	2547	49
80.0	20270	3640	105	27460	3421	310	8200	2646	52
85.0	21270	3739	109	29620	3520	323	8580	2745	54
90.0	22360	3838	113	32050	3619	477	8990	2844	56

**Caption**

TH: Tower height  
 H: Horizontal load  
 STR: M  
 Fall Torque  
 V Vertical load

# WOLFFKRAN

Static data

## 12.1.2 Foundation loads jib 65-70 m

Slewing section with 65-70 m jib on foundation

Slewing tower crane without climbing frame

TH	Crane in service			Crane out of service			Assembly		
	Slewing torque: 750 kNm			Wind region C25					
	M	V	H	M	V	H	M	V	H
[m]	[kNm]	[kN]	[kN]	[kNm]	[kN]	[kN]	[kNm]	[kN]	[kN]
5.0	12410	2121	42	9320	1967	119	7400	1192	17
10.0	12640	2220	46	9960	2066	132	7500	1291	19
15.0	12910	2319	50	10670	2165	145	7610	1390	22
20.0	13210	2418	54	11460	2264	159	7740	1489	24
25.0	13550	2517	58	12330	2363	172	7880	1588	26
30.0	13930	2616	62	13290	2462	185	8040	1687	29
35.0	14340	2715	67	14330	2561	198	8220	1786	31
40.0	14800	2814	71	15470	2660	212	8420	1885	33
45.0	15300	2913	75	16690	2759	225	8630	1984	36
50.0	15840	3012	79	18020	2858	238	8870	2083	38
55.0	16440	3111	83	19450	2957	252	9130	2182	40
60.0	17080	3210	87	20990	3056	265	9410	2281	43
65.0	17790	3309	92	22650	3155	278	9720	2380	45
70.0	18560	3408	96	24440	3254	291	10050	2479	47
75.0	19390	3507	100	26360	3353	305	10410	2578	50
80.0	20300	3606	104	28580	3452	434	10800	2677	52
85.0	21290	3705	108	31930	3551	458	11220	2776	54

**Caption**

TH: Tower height  
 H: Horizontal load  
 STR: M  
 Fall Torque  
 V Vertical load

# WOLFFKRAN

Static data

## 12.1.3 Foundation loads jib 75-80 m

Slewing section with 75-80 m jib on foundation

Slewing tower crane without climbing frame

TH	Crane in service			Crane out of service			Assembly		
	Slewing torque: 750 kNm			Wind region C25					
	M	V	H	M	V	H	M	V	H
[m]	[kNm]	[kN]	[kN]	[kNm]	[kN]	[kN]	[kNm]	[kN]	[kN]
5.0	12400	2098	41	9930	1988	127	9240	1213	17
10.0	12630	2197	45	10610	2087	141	9330	1312	19
15.0	12890	2296	49	11370	2186	154	9450	1411	22
20.0	13190	2395	53	12210	2285	167	9580	1510	24
25.0	13520	2494	58	13130	2384	180	9730	1609	26
30.0	13890	2593	62	14130	2483	194	9900	1708	29
35.0	14020	2582	79	15220	2582	207	10090	1807	31
40.0	14530	2681	84	16410	2681	220	10300	1906	33
45.0	15080	2780	88	17680	2780	233	10520	2005	36
50.0	15680	2879	92	19060	2879	247	10780	2104	38
55.0	16320	2978	96	20550	2978	260	11050	2203	40
60.0	17020	3077	100	22150	3077	273	11350	2302	43
65.0	17780	3176	104	23870	3176	287	11680	2401	45
70.0	18590	3275	108	25720	3275	300	12040	2500	47
75.0	19470	3374	113	28070	3374	414	12420	2599	50
80.0	20420	3473	117	31220	3473	438	12840	2698	52

**Caption**

TH: Tower height  
 H: Horizontal load  
 STR: M  
 Fall Torque  
 V: Vertical load

# WOLFFKRAN

Static data

## 12.1.4 Slewing section with 40 m Jib on KRE4120

Slewing section with 40 m Jib on KRE4120

Slewing tower crane without climbing frame

X Stationary  
 Mobile

Corner distance: 12.0 m x 12.0 m

TH	ZB	ALS	Crane in service					Crane out of service					
			Slewing torque: 750 kNm					Wind region: C25					
			A	B	C	D	H	A	B	C	D	H	
[m]	[t]		[kN]	[kN]	[kN]	[kN]	[kN]	[kN]	[kN]	[kN]	[kN]	[kN]	[kN]
18.7	0	1	559	1410	559	0	75	632	809	632	455	173	
		2	1194	1194	369	369		757	757	506	506		
23.7	0	1	591	1445	591	0	79	656	774	656	538	193	
		2	1235	1235	377	377		740	740	573	573		
28.7	0	1	621	1484	621	0	83	681	733	681	630	214	
		2	1278	1278	384	384		718	718	645	645		
33.7	0	1	649	1527	649	0	87	706	748	706	664	235	
		2	1322	1322	390	390		735	735	676	676		
38.7	0	1	674	1574	674	0	91	731	853	731	609	256	
		2	1367	1367	394	394		817	817	644	644		
43.7	0	1	905	1626	905	185	96	755	966	755	545	277	
		2	1415	1415	396	396		904	904	607	607		
48.7	0	1	930	1684	930	176	100	780	1087	780	473	299	
		2	1463	1463	397	397		997	997	563	563		
53.7	0	1	955	1746	955	164	104	805	1218	805	392	321	
		2	1514	1514	396	396		1097	1097	513	513		
58.7	0	1	980	1810	980	149	108	830	1358	830	302	343	
		2	1567	1567	392	392		1203	1203	456	456		
63.7	0	1	769	1880	769	0	112	854	1508	854	201	366	
		2	1622	1622	387	387		1316	1316	393	393		
68.7	0	1	780	1957	780	0	116	879	1668	879	90	389	
		2	1679	1679	379	379		1437	1437	321	321		
73.7	15	1	1091	2060	1091	122	120	941	1877	941	6	412	
		2	1777	1777	406	406		1603	1603	280	280		
78.7	35	1	1166	2189	1166	144	125	939	2188	939	0	436	
		2	1889	1889	443	443		1790	1790	242	242		
83.7	55	1	1241	2321	1241	160	129	917	2531	917	0	459	
		2	2005	2005	477	477		1986	1986	196	196		
88.7	80	1	1328	2472	1328	185	133	906	2902	906	0	483	
		2	2137	2137	520	520		2204	2204	152	152		

**Caption**

TH: Tower height  
 ALS: Jib position  
 ZB: Central ballast  
 H: Horizontal load

# WOLFFKRAN

Static data

## 12.1.5 Slewing section with 45 m Jib on KRE4120

Slewing section with 45 m Jib on KRE4120

Slewing tower crane without climbing frame

X Stationary  
Mobile

Corner distance: 12.0 m x 12.0 m

			Crane in service					Crane out of service					
			Slewing torque: 750 kNm					Wind region: C25					
TH	ZB	ALS	Corner loads					Corner loads					
			A	B	C	D	H	A	B	C	D	H	
[m]	[t]		[kN]	[kN]	[kN]	[kN]	[kN]	[kN]	[kN]	[kN]	[kN]	[kN]	[kN]
18.7	0	1	564	1418	564	0	76	636	779	636	494	179	
		2	1204	1204	368	368		737	737	536	536		
23.7	0	1	595	1454	595	0	81	661	743	661	580	199	
		2	1246	1246	376	376		719	719	604	604		
28.7	0	1	625	1495	625	0	85	686	718	686	654	220	
		2	1289	1289	383	383		709	709	663	663		
33.7	0	1	652	1539	652	0	89	711	816	711	605	241	
		2	1333	1333	388	388		785	785	636	636		
38.7	0	1	678	1587	678	0	93	735	922	735	549	262	
		2	1379	1379	392	392		867	867	604	604		
43.7	0	1	910	1640	910	180	97	760	1036	760	485	283	
		2	1427	1427	394	394		955	955	565	565		
48.7	0	1	935	1700	935	170	101	785	1158	785	412	305	
		2	1476	1476	394	394		1049	1049	521	521		
53.7	0	1	960	1762	960	157	105	810	1290	810	329	327	
		2	1527	1527	392	392		1149	1149	470	470		
58.7	0	1	984	1827	984	142	110	834	1431	834	238	350	
		2	1580	1580	388	388		1256	1256	413	413		
63.7	0	1	769	1899	769	0	114	859	1582	859	136	373	
		2	1636	1636	382	382		1370	1370	348	348		
68.7	0	1	779	1977	779	0	118	884	1744	884	24	396	
		2	1694	1694	374	374		1492	1492	276	276		
73.7	15	1	1096	2080	1096	113	122	884	2016	884	0	419	
		2	1792	1792	401	401		1659	1659	233	233		
78.7	35	1	1171	2209	1171	133	126	873	2337	873	0	442	
		2	1905	1905	437	437		1847	1847	194	194		
83.7	55	1	1246	2343	1246	149	130	850	2684	850	0	466	
		2	2021	2021	470	470		2045	2045	146	146		
88.7	95	1	1370	2531	1370	210	135	911	3059	911	0	490	
		2	2191	2191	560	560		2302	2302	139	139		

**Caption**

TH: Tower height  
ALS: Jib position

ZB: Central ballast  
H: Horizontal load

# WOLFFKRAN

Static data

## 12.1.6 Slewing section with 50 m Jib on KRE4120

Slewing section with 50 m Jib on KRE4120

Slewing tower crane without climbing frame

X Stationary  
Mobile

Corner distance: 12.0 m x 12.0 m

			Crane in service					Crane out of service					
			Slewing torque: 750 kNm					Wind region: C25					
TH	ZB	ALS	Corner loads					Corner loads					
			A	B	C	D	H	A	B	C	D	H	
[m]	[t]		[kN]	[kN]	[kN]	[kN]	[kN]	[kN]	[kN]	[kN]	[kN]	[kN]	[kN]
18.7	0	1	570	1425	570	0	78	641	773	641	510	189	
		2	1215	1215	367	367		734	734	548	548		
23.7	0	1	601	1463	601	0	83	666	732	666	599	210	
		2	1257	1257	375	375		713	713	619	619		
28.7	0	1	630	1504	630	0	87	691	792	691	589	230	
		2	1300	1300	381	381		762	762	619	619		
33.7	0	1	656	1549	656	0	91	715	891	715	540	251	
		2	1345	1345	386	386		839	839	591	591		
38.7	0	1	690	1599	690	181	95	740	998	740	483	273	
		2	1391	1391	389	389		922	922	558	558		
43.7	0	1	915	1657	915	173	99	765	1113	765	417	294	
		2	1439	1439	390	390		1011	1011	519	519		
48.7	0	1	940	1717	940	162	103	790	1236	790	343	316	
		2	1489	1489	390	390		1105	1105	474	474		
53.7	0	1	964	1780	964	149	107	814	1369	814	260	338	
		2	1541	1541	388	388		1207	1207	422	422		
58.7	0	1	989	1846	989	133	112	839	1511	839	167	361	
		2	1595	1595	383	383		1315	1315	364	364		
63.7	0	1	769	1917	769	0	116	864	1664	864	64	384	
		2	1651	1651	377	377		1430	1430	298	298		
68.7	15	1	1076	2025	1076	128	120	914	1877	914	0	407	
		2	1747	1747	405	405		1590	1590	262	262		
73.7	35	1	1151	2151	1151	151	124	913	2177	913	0	430	
		2	1858	1858	444	444		1771	1771	231	231		
78.7	55	1	1226	2281	1226	170	128	901	2502	901	0	454	
		2	1972	1972	479	479		1960	1960	191	191		
83.7	75	1	1300	2416	1300	185	132	874	2853	874	0	477	
		2	2089	2089	512	512		2159	2159	141	141		
88.7	120	1	1438	2618	1438	257	137	959	3233	959	0	501	
		2	2273	2273	603	603		2431	2431	144	144		

**Caption**

TH: Tower height  
ALS: Jib position

ZB: Central ballast  
H: Horizontal load

# WOLFFKRAN

Static data

## 12.1.7 Slewing section with 55 m Jib on KRE4120

Slewing section with 55 m Jib on KRE4120

Slewing tower crane without climbing frame

X Stationary  
Mobile

Corner distance: 12.0 m x 12.0 m

TH	ZB	ALS	Crane in service					Crane out of service				
			Slewing torque:					Wind region:				
			750 kNm					C25				
			Corner loads					Corner loads				
[m]	[t]		A	B	C	D	H	A	B	C	D	H
[kN]	[kN]	[kN]	[kN]	[kN]	[kN]	[kN]	[kN]	[kN]	[kN]	[kN]	[kN]	[kN]
18.7	0	1	571	1435	571	0	80	644	745	644	544	196
		2	1218	1218	371	371		715	715	573	573	
23.7	0	1	602	1473	602	0	84	669	763	669	575	216
		2	1260	1260	378	378		735	735	603	603	
28.7	0	1	630	1516	630	0	88	694	855	694	533	237
		2	1304	1304	384	384		808	808	580	580	
33.7	0	1	656	1562	656	0	92	719	954	719	483	258
		2	1349	1349	388	388		885	885	552	552	
38.7	0	1	680	1613	680	0	97	743	1062	743	425	280
		2	1396	1396	391	391		968	968	518	518	
43.7	0	1	702	1668	702	0	101	768	1178	768	358	301
		2	1444	1444	392	392		1058	1058	478	478	
48.7	0	1	722	1728	722	0	105	793	1302	793	283	323
		2	1494	1494	391	391		1153	1153	432	432	
53.7	0	1	739	1792	739	0	109	818	1436	818	199	346
		2	1546	1546	389	389		1255	1255	380	380	
58.7	0	1	754	1862	754	0	113	842	1580	842	105	368
		2	1601	1601	384	384		1364	1364	321	321	
63.7	5	1	790	1938	790	0	117	880	1746	880	13	391
		2	1670	1670	389	389		1492	1492	267	267	
68.7	20	1	1092	2045	1092	138	121	877	2013	877	0	414
		2	1766	1766	418	418		1654	1654	230	230	
73.7	40	1	1167	2172	1167	161	126	875	2317	875	0	438
		2	1877	1877	456	456		1836	1836	197	197	
78.7	60	1	1241	2303	1241	180	130	860	2645	860	0	461
		2	1992	1992	491	491		2027	2027	156	156	
83.7	90	1	1341	2463	1341	219	134	882	3000	882	0	485
		2	2135	2135	547	547		2252	2252	130	130	
88.7	140	1	1491	2679	1491	303	138	990	3384	990	0	509
		2	2331	2331	651	651		2537	2537	144	144	

**Caption**

TH: Tower height  
ALS: Jib position

ZB: Central ballast  
H: Horizontal load

# WOLFFKRAN

Static data

## 12.1.8 Slewing section with 60 m Jib on KRE4120

Slewing section with 60 m Jib on KRE4120

Slewing tower crane without climbing frame

X Stationary  
Mobile

Corner distance: 12.0 m x 12.0 m

TH	ZB	ALS	Crane in service					Crane out of service				
			Slewing torque:					Wind region:				
			750 kNm					C25				
			Corner loads					Corner loads				
[m]	[t]		A	B	C	D	H	A	B	C	D	H
[kN]	[kN]	[kN]	[kN]	[kN]	[kN]	[kN]	[kN]	[kN]	[kN]	[kN]	[kN]	[kN]
18.7	0	1	577	1443	577	0	82	455	770	455	140	203
		2	1228	1228	370	370		728	728	570	570	
23.7	0	1	607	1482	607	0	86	674	845	674	502	224
		2	1271	1271	377	377		795	795	552	552	
28.7	0	1	634	1526	634	0	90	699	938	699	459	244
		2	1315	1315	382	382		868	868	529	529	
33.7	0	1	660	1574	660	0	94	723	1038	723	408	265
		2	1361	1361	386	386		946	946	500	500	
38.7	0	1	684	1625	684	0	98	748	1147	748	349	287
		2	1408	1408	388	388		1030	1030	466	466	
43.7	0	1	705	1682	705	0	103	773	1264	773	282	309
		2	1457	1457	389	389		1120	1120	426	426	
48.7	0	1	724	1743	724	0	107	798	1390	798	205	331
		2	1507	1507	388	388		1216	1216	379	379	
53.7	0	1	740	1809	740	0	111	822	1525	822	120	353
		2	1560	1560	384	384		1319	1319	325	325	
58.7	0	1	754	1880	754	0	115	847	1670	847	24	376
		2	1615	1615	379	379		1429	1429	265	265	
63.7	5	1	790	1957	790	0	119	815	1907	815	0	399
		2	1684	1684	384	384		1559	1559	210	210	
68.7	25	1	1109	2078	1109	140	123	823	2191	823	0	422
		2	1794	1794	424	424		1734	1734	184	184	
73.7	45	1	1184	2205	1184	162	128	819	2498	819	0	445
		2	1906	1906	461	461		1917	1917	150	150	
78.7	70	1	1271	2350	1271	192	132	827	2831	827	0	469
		2	2034	2034	508	508		2122	2122	120	120	
83.7	115	1	1408	2549	1408	268	136	921	3191	921	0	493
		2	2215	2215	602	602		2367	2367	130	130	

**Caption**

TH: Tower height  
ALS: Jib position

ZB: Central ballast  
H: Horizontal load

# WOLFFKRAN

Static data

## 12.1.9 Slewing section with 65 m Jib on KRE4120

Slewing section with 65 m Jib on KRE4120

Slewing tower crane without climbing frame

X Stationary  
Mobile

Corner distance: 12.0 m x 12.0 m

			Crane in service					Crane out of service					
			Slewing torque:					Wind region:					
			750 kNm					C25					
TH	ZB	ALS	Corner loads					Corner loads					
			A	B	C	D	H	A	B	C	D	H	
[m]	[t]		[kN]	[kN]	[kN]	[kN]	[kN]	[kN]	[kN]	[kN]	[kN]	[kN]	[kN]
18.7	0	1	578	1453	578	0	83	458	832	458	84	210	
		2	1231	1231	373	373		778	778	526	526		
23.7	0	1	607	1494	607	0	87	677	916	677	438	231	
		2	1274	1274	379	379		846	846	508	508		
28.7	0	1	634	1539	634	0	92	702	1009	702	394	251	
		2	1319	1319	384	384		919	919	484	484		
33.7	0	1	659	1587	659	0	96	726	1111	726	342	273	
		2	1365	1365	388	388		998	998	454	454		
38.7	0	1	682	1640	682	0	100	751	1220	751	282	294	
		2	1412	1412	390	390		1083	1083	419	419		
43.7	0	1	703	1698	703	0	104	776	1338	776	213	316	
		2	1461	1461	390	390		1174	1174	378	378		
48.7	0	1	721	1760	721	0	108	801	1465	801	136	338	
		2	1512	1512	389	389		1271	1271	330	330		
53.7	0	1	737	1827	737	0	112	825	1602	825	48	360	
		2	1565	1565	385	385		1375	1375	276	276		
58.7	0	1	750	1900	750	0	116	802	1797	802	0	383	
		2	1620	1620	380	380		1485	1485	215	215		
63.7	10	1	811	1978	811	0	121	769	2062	769	0	406	
		2	1703	1703	397	397		1629	1629	171	171		
68.7	30	1	1125	2098	1125	151	125	775	2349	775	0	429	
		2	1813	1813	436	436		1805	1805	144	144		
73.7	50	1	1199	2226	1199	172	129	769	2660	769	0	453	
		2	1925	1925	473	473		1990	1990	109	109		
78.7	90	1	1324	2409	1324	239	133	850	2997	850	0	477	
		2	2091	2091	557	557		2234	2234	114	114		
83.7	140	1	1474	2621	1474	327	137	967	3361	967	0	501	
		2	2285	2285	663	663		2512	2512	135	135		

**Caption**

TH: Tower height  
ALS: Jib position

ZB: Central ballast  
H: Horizontal load

# WOLFFKRAN

Static data

## 12.1.10 Slewing section with 70 m Jib on KRE4120

Slewing section with 70 m Jib on KRE4120

Slewing tower crane without climbing frame

X Stationary  
Mobile

Corner distance: 12.0 m x 12.0 m

			Crane in service					Crane out of service				
			Slewing torque:					Wind region:				
			750 kNm					C25				
TH	ZB	ALS	Corner loads					Corner loads				
			A	B	C	D	H	A	B	C	D	H
[m]	[t]		[kN]	[kN]	[kN]	[kN]	[kN]	[kN]	[kN]	[kN]	[kN]	[kN]
18.7	0	1	585	1458	585	0	82	657	922	657	392	218
		2	1220	1220	343	343		844	844	469	469	
23.7	0	1	613	1500	613	0	86	682	1009	682	354	238
		2	1263	1263	350	350		913	913	450	450	
28.7	0	1	640	1545	640	0	90	706	1103	706	309	259
		2	1307	1307	356	356		987	987	426	426	
33.7	0	1	665	1595	665	0	94	731	1205	731	257	280
		2	1352	1352	360	360		1066	1066	396	396	
38.7	0	1	687	1649	687	0	98	756	1316	756	195	301
		2	1399	1399	362	362		1152	1152	359	359	
43.7	0	1	708	1707	708	0	103	781	1436	781	125	323
		2	1448	1448	363	363		1244	1244	317	317	
48.7	0	1	725	1771	725	0	107	805	1564	805	46	346
		2	1499	1499	362	362		1342	1342	269	269	
53.7	0	1	741	1839	741	0	111	788	1744	788	0	368
		2	1552	1552	358	358		1447	1447	213	213	
58.7	0	1	753	1913	753	0	115	714	1991	714	0	391
		2	1606	1606	353	353		1559	1559	151	151	
63.7	15	1	838	1993	838	0	119	704	2260	704	0	414
		2	1701	1701	383	383		1716	1716	118	118	
68.7	35	1	1117	2097	1117	136	123	708	2551	708	0	437
		2	1810	1810	424	424		1894	1894	90	90	
73.7	75	1	1242	2275	1242	208	127	800	2867	800	0	461
		2	1972	1972	511	511		2130	2130	103	103	
78.7	120	1	1379	2469	1379	289	132	903	3209	903	0	484
		2	2149	2149	608	608		2388	2388	119	119	
83.7	165	1	1516	2667	1516	365	136	993	3579	993	0	508
		2	2330	2330	702	702		2657	2657	125	125	

**Caption**

TH: Tower height  
ALS: Jib position

ZB: Central ballast  
H: Horizontal load



# WOLFFKRAN

Static data

## 12.1.11 Slewing section with 75 m Jib on KRE4120

Slewing section with 75 m Jib on KRE4120

Slewing tower crane without climbing frame

X Stationary  
Mobile

Corner distance: 12.0 m x 12.0 m

			Crane in service					Crane out of service					
			Slewing torque:					Wind region:					
			750 kNm					C25					
TH	ZB	ALS	Corner loads					Corner loads					
			A	B	C	D	H	A	B	C	D	H	
[m]	[t]		[kN]	[kN]	[kN]	[kN]	[kN]	[kN]	[kN]	[kN]	[kN]	[kN]	[kN]
18.7	0	1	578	1474	578	0	79	657	953	657	361	225	
		2	1193	1193	183	183		866	866	448	448		
23.7	0	1	606	1517	606	0	83	682	1040	682	324	246	
		2	1231	1231	195	195		935	935	429	429		
28.7	0	1	632	1563	632	0	88	707	1136	707	278	266	
		2	1270	1270	206	206		1010	1010	404	404		
33.7	0	1	656	1614	656	0	92	732	1239	732	224	288	
		2	1310	1310	215	215		1090	1090	373	373		
38.7	0	1	678	1669	678	0	96	756	1350	756	163	309	
		2	1356	1356	357	357		1176	1176	336	336		
43.7	0	1	698	1728	698	0	100	781	1470	781	92	331	
		2	1404	1404	358	358		1268	1268	294	294		
48.7	0	1	715	1793	715	0	104	806	1599	806	12	353	
		2	1454	1454	358	358		1367	1367	245	245		
53.7	0	1	730	1862	730	0	108	754	1815	754	0	376	
		2	1505	1505	356	356		1472	1472	189	189		
58.7	10	1	792	1937	792	0	112	729	2064	729	0	399	
		2	1584	1584	377	377		1610	1610	150	150		
63.7	30	1	901	2018	901	0	117	743	2334	743	0	422	
		2	1690	1690	420	420		1780	1780	130	130		
68.7	50	1	1007	2105	1007	0	121	746	2628	746	0	445	
		2	1798	1798	462	462		1959	1959	101	101		
73.7	90	1	1155	2254	1155	55	125	837	2946	837	0	469	
		2	1959	1959	550	550		2196	2196	113	113		
78.7	130	1	1379	2430	1379	329	129	914	3290	914	0	493	
		2	2122	2122	637	637		2443	2443	116	116		

**Caption**

TH: Tower height  
ALS: Jib position

ZB: Central ballast  
H: Horizontal load

# WOLFFKRAN

Static data

## 12.1.12 Slewing section with 80 m Jib on KRE4120

Slewing section with 80 m Jib on KRE4120

Slewing tower crane without climbing frame

X Stationary  
Mobile

Corner distance: 12.0 m x 12.0 m

			Crane in service					Crane out of service				
			Slewing torque:					Wind region:				
			750 kNm					C25				
TH	ZB	ALS	Corner loads					Corner loads				
			A	B	C	D	H	A	B	C	D	H
[m]	[t]		[kN]	[kN]	[kN]	[kN]	[kN]	[kN]	[kN]	[kN]	[kN]	[kN]
18.7	10	1	632	1484	632	0	81	425	1123	425	0	233
		2	1225	1225	199	199		962	962	412	412	
23.7	10	1	660	1528	660	0	85	712	1164	712	260	253
		2	1263	1263	211	211		1031	1031	392	392	
28.7	10	1	685	1576	685	0	89	737	1260	737	213	274
		2	1301	1301	222	222		1106	1106	367	367	
33.7	10	1	709	1628	709	0	93	761	1364	761	159	295
		2	1342	1342	231	231		1187	1187	335	335	
38.7	10	1	730	1684	730	0	98	786	1476	786	96	317
		2	1384	1384	238	238		1274	1274	298	298	
43.7	10	1	749	1745	749	0	102	811	1597	811	24	339
		2	1428	1428	194	194		1367	1367	254	254	
48.7	10	1	766	1810	766	0	106	779	1785	779	0	361
		2	1476	1476	195	195		1467	1467	204	204	
53.7	10	1	780	1881	780	0	110	713	2016	713	0	384
		2	1526	1526	195	195		1573	1573	147	147	
58.7	15	1	816	1958	816	0	114	661	2268	661	0	407
		2	1591	1591	404	404		1700	1700	95	95	
63.7	40	1	950	2040	950	0	118	699	2542	699	0	430
		2	1709	1709	460	460		1884	1884	86	86	
68.7	75	1	1097	2161	1097	33	122	775	2839	775	0	453
		2	1855	1855	539	539		2101	2101	93	93	
73.7	115	1	1222	2334	1222	110	127	863	3162	863	0	477
		2	2016	2016	627	627		2340	2340	104	104	
78.7	160	1	1359	2523	1359	195	131	963	3511	963	0	501
		2	2192	2192	726	726		2600	2600	118	118	

**Caption**

TH: Tower height  
ALS: Jib position

ZB: Central ballast  
H: Horizontal load

# WOLFFKRAN

Static data

## 12.1.13 Slewing section with 40 m Jib on UW4120

Slewing section with 40 m Jib on UW4120

Slewing tower crane without climbing frame

X Stationary  
Mobile

Corner distance: 12.0 m x 12.0 m

			Crane in service					Crane out of service					
			Slewing torque:					Wind region:					
			750 kNm					C25					
TH	ZB	ALS	Corner loads					Corner loads					
			A	B	C	D	H	A	B	C	D	H	
[m]	[t]		[kN]	[kN]	[kN]	[kN]	[kN]	[kN]	[kN]	[kN]	[kN]	[kN]	[kN]
20	0	1	565	1537	565	46	106	678	841	678	515	176	
		2	1286	1286	370	370	793	793	562	562			
25	0	1	589	1588	589	46	111	703	805	703	600	196	
		2	1334	1334	371	371	775	775	630	630			
30	0	1	610	1643	610	46	116	727	761	727	694	217	
		2	1384	1384	371	371	751	751	703	703			
35	0	1	630	1703	630	46	122	752	814	752	691	237	
		2	1436	1436	369	369	796	796	709	709			
40	0	1	646	1769	646	46	127	777	921	777	633	259	
		2	1489	1489	364	364	879	879	675	675			
45	0	1	660	1840	660	46	132	802	1037	802	566	280	
		2	1545	1545	358	358	968	968	635	635			
50	0	1	671	1917	671	46	137	826	1162	826	490	302	
		2	1604	1604	349	349	1064	1064	589	589			
55	0	1	679	2000	679	46	142	851	1297	851	405	324	
		2	1664	1664	338	338	1166	1166	536	536			
60	0	1	684	2089	684	46	147	876	1441	876	311	347	
		2	1728	1728	324	324	1276	1276	476	476			
65	0	1	685	2186	685	46	152	901	1596	901	205	369	
		2	1794	1794	307	307	1392	1392	409	409			
70	10	1	733	2290	733	46	157	950	1787	950	113	392	
		2	1889	1889	312	312	1542	1542	359	359			
75	25	1	1097	2412	1097	46	163	989	2027	989	46	416	
		2	1999	1999	326	326	1713	1713	312	312			

**Caption**

TH: Tower height  
ALS: Jib position  
ZB: Central ballast  
H: Horizontal load

# WOLFFKRAN

Static data

## 12.1.14 Slewing section with 45 m Jib on UW4120

Slewing section with 45 m Jib on UW4120

Slewing tower crane without climbing frame

X Stationary  
Mobile

Corner distance: 12.0 m x 12.0 m

			Crane in service					Crane out of service				
			Slewing torque:					Wind region:				
			750 kNm					C25				
TH	ZB	ALS	Corner loads					Corner loads				
			A	B	C	D	H	A	B	C	D	H
[m]	[t]		[kN]	[kN]	[kN]	[kN]	[kN]	[kN]	[kN]	[kN]	[kN]	[kN]
20	0	1	569	1547	569	46	108	683	811	683	555	182
		2	1298	1298	367	367	773	773	592	592		
25	0	1	593	1599	593	46	113	707	772	707	642	202
		2	1347	1347	368	368	753	753	661	661		
30	0	1	614	1656	614	46	118	732	782	732	682	223
		2	1397	1397	367	367	768	768	697	697		
35	0	1	632	1717	632	46	123	757	883	757	631	243
		2	1449	1449	365	365	846	846	668	668		
40	0	1	648	1784	648	46	128	782	991	782	572	265
		2	1504	1504	360	360	930	930	634	634		
45	0	1	662	1857	662	46	134	806	1108	806	505	286
		2	1560	1560	353	353	1020	1020	593	593		
50	0	1	672	1935	672	46	139	831	1234	831	428	308
		2	1619	1619	344	344	1116	1116	546	546		
55	0	1	679	2020	679	46	144	856	1370	856	342	331
		2	1680	1680	332	332	1219	1219	492	492		
60	0	1	683	2111	683	46	149	881	1516	881	246	353
		2	1744	1744	317	317	1330	1330	432	432		
65	0	1	683	2209	683	46	154	905	1672	905	139	376
		2	1811	1811	300	300	1448	1448	363	363		
70	10	1	730	2315	730	46	159	955	1866	955	46	399
		2	1906	1906	304	304	1599	1599	312	312		
75	30	1	1112	2451	1112	46	164	949	2176	949	46	422
		2	2030	2030	330	330	1783	1783	277	277		

**Caption**

TH: Tower height  
ALS: Jib position  
ZB: Central ballast  
H: Horizontal load

# WOLFFKRAN

Static data

## 12.1.15 Slewing section with 50 m Jib on UW4120

Slewing section with 50 m Jib on UW4120

Slewing tower crane without climbing frame

X Stationary  
Mobile

Corner distance: 12.0 m x 12.0 m

TH	ZB	ALS	Crane in service					Crane out of service					
			Slewing torque:					Wind region:					
			750 kNm					C25					
			Corner loads				Corner loads						
[m]	[t]		A [kN]	B [kN]	C [kN]	D [kN]	H [kN]	A [kN]	B [kN]	C [kN]	D [kN]	H [kN]	
20	0	1	574	1556	574	46	110	687	804	687	571	192	
		2	1311	1311	363	363		770	770	605	605		
25	0	1	597	1610	597	46	115	712	764	712	661	212	
		2	1360	1360	364	364		748	748	676	676		
30	0	1	617	1668	617	46	120	737	857	737	617	233	
		2	1411	1411	363	363		822	822	652	652		
35	0	1	635	1731	635	46	125	762	958	762	565	254	
		2	1464	1464	359	359		901	901	623	623		
40	0	1	650	1799	650	46	131	786	1068	786	505	275	
		2	1519	1519	354	354		985	985	588	588		
45	0	1	663	1873	663	46	136	811	1186	811	436	297	
		2	1576	1576	346	346		1076	1076	546	546		
50	0	1	673	1953	673	46	141	836	1313	836	359	319	
		2	1635	1635	336	336		1173	1173	498	498		
55	0	1	679	2039	679	46	146	861	1450	861	271	342	
		2	1697	1697	324	324		1278	1278	444	444		
60	0	1	682	2131	682	46	151	885	1598	885	173	364	
		2	1762	1762	309	309		1389	1389	382	382		
65	10	1	732	2231	732	46	156	935	1781	935	90	387	
		2	1855	1855	316	316		1533	1533	337	337		
70	30	1	1120	2354	1120	46	161	984	2027	984	46	410	
		2	1976	1976	344	344		1710	1710	310	310		
75	50	1	1199	2495	1199	46	167	976	2341	976	46	434	
		2	2101	2101	369	369		1896	1896	273	273		

**Caption**

TH: Tower height  
ALS: Jib position

ZB: Central ballast  
H: Horizontal load

# WOLFFKRAN

Static data

## 12.1.16 Slewing section with 55 m Jib on UW4120

Slewing section with 55 m Jib on UW4120

Slewing tower crane without climbing frame

X Stationary  
Mobile

Corner distance: 12.0 m x 12.0 m

TH	ZB	ALS	Crane in service					Crane out of service					
			Slewing torque:					Wind region:					
			750 kNm					C25					
			Corner loads				Corner loads						
[m]	[t]		A [kN]	B [kN]	C [kN]	D [kN]	H [kN]	A [kN]	B [kN]	C [kN]	D [kN]	H [kN]	
20	0	1	574	1568	574	46	112	691	775	691	606	199	
		2	1316	1316	365	365		750	750	631	631		
25	0	1	597	1622	597	46	117	715	826	715	605	219	
		2	1366	1366	365	365		793	793	637	637		
30	0	1	617	1681	617	46	122	740	920	740	560	240	
		2	1417	1417	363	363		867	867	613	613		
35	0	1	634	1746	634	46	127	765	1022	765	507	261	
		2	1470	1470	359	359		947	947	583	583		
40	0	1	649	1815	649	46	132	790	1133	790	446	282	
		2	1525	1525	354	354		1032	1032	547	547		
45	0	1	660	1890	660	46	137	814	1252	814	377	304	
		2	1583	1583	346	346		1124	1124	505	505		
50	0	1	669	1972	669	46	142	839	1380	839	298	326	
		2	1643	1643	335	335		1222	1222	456	456		
55	0	1	675	2059	675	46	148	864	1519	864	209	349	
		2	1705	1705	323	323		1327	1327	401	401		
60	0	1	678	2153	678	46	153	889	1667	889	110	371	
		2	1770	1770	307	307		1439	1439	338	338		
65	15	1	751	2255	751	46	158	942	1873	942	46	394	
		2	1876	1876	326	326		1597	1597	305	305		
70	35	1	1143	2370	1143	46	163	945	2166	945	46	418	
		2	1997	1997	354	354		1775	1775	276	276		
75	55	1	1221	2513	1221	46	168	936	2484	936	46	441	
		2	2123	2123	378	378		1962	1962	238	238		

**Caption**

TH: Tower height  
ALS: Jib position

ZB: Central ballast  
H: Horizontal load

# WOLFFKRAN

Static data

## 12.1.17 Slewing section with 60 m Jib on UW4120

Slewing section with 60 m Jib on UW4120

Slewing tower crane without climbing frame

X Stationary  
Mobile

Corner distance: 12.0 m x 12.0 m

			Crane in service					Crane out of service					
			Slewing torque:					Wind region:					
			750 kNm					C25					
TH	ZB	ALS	Corner loads					Corner loads					
[m]	[t]		A	B	C	D	H	A	B	C	D	H	
			[kN]	[kN]	[kN]	[kN]	[kN]	[kN]	[kN]	[kN]	[kN]	[kN]	[kN]
20	5	1	604	1578	604	46	114	708	834	708	582	206	
		2	1342	1342	374	374		797	797	619	619		
25	5	1	625	1634	625	46	119	733	921	733	544	226	
		2	1392	1392	373	373		866	866	599	599		
30	5	1	645	1694	645	46	124	757	1016	757	498	247	
		2	1443	1443	371	371		940	940	574	574		
35	5	1	661	1760	661	46	129	782	1119	782	445	268	
		2	1497	1497	367	367		1021	1021	543	543		
40	5	1	675	1831	675	46	134	807	1231	807	382	290	
		2	1553	1553	361	361		1107	1107	507	507		
45	5	1	686	1907	686	46	140	832	1352	832	311	312	
		2	1611	1611	352	352		1199	1199	464	464		
50	5	1	695	1990	695	46	145	856	1481	856	231	334	
		2	1671	1671	341	341		1298	1298	414	414		
55	5	1	700	2079	700	46	150	881	1621	881	141	356	
		2	1735	1735	327	327		1404	1404	358	358		
60	5	1	701	2175	701	46	155	900	1777	900	46	379	
		2	1800	1800	311	311		1518	1518	294	294		
65	20	1	774	2278	774	46	160	888	2051	888	46	402	
		2	1907	1907	329	329		1677	1677	259	259		
70	35	1	1132	2412	1132	46	165	864	2348	864	46	425	
		2	2017	2017	344	344		1844	1844	216	216		

**Caption**

TH: Tower height  
ALS: Jib position  
ZB: Central ballast  
H: Horizontal load

# WOLFFKRAN

Static data

## 12.1.18 Slewing section with 65 m Jib on UW4120

Slewing section with 65 m Jib on UW4120

Slewing tower crane without climbing frame

X Stationary  
Mobile

Corner distance: 12.0 m x 12.0 m

			Crane in service					Crane out of service					
			Slewing torque:					Wind region:					
			750 kNm					C25					
TH	ZB	ALS	Corner loads					Corner loads					
[m]	[t]		A	B	C	D	H	A	B	C	D	H	
			[kN]	[kN]	[kN]	[kN]	[kN]	[kN]	[kN]	[kN]	[kN]	[kN]	[kN]
20	0	1	579	1590	579	46	115	698	892	698	505	213	
		2	1334	1334	362	362		835	835	562	562		
25	0	1	600	1647	600	46	120	723	980	723	466	233	
		2	1384	1384	362	362		905	905	541	541		
30	0	1	618	1709	618	46	126	748	1076	748	420	254	
		2	1437	1437	359	359		980	980	516	516		
35	0	1	634	1776	634	46	131	773	1180	773	365	275	
		2	1491	1491	354	354		1061	1061	484	484		
40	0	1	648	1848	648	46	136	797	1293	797	302	297	
		2	1547	1547	348	348		1148	1148	447	447		
45	0	1	658	1926	658	46	141	822	1415	822	229	319	
		2	1605	1605	339	339		1241	1241	403	403		
50	0	1	666	2010	666	46	146	847	1546	847	148	341	
		2	1666	1666	328	328		1341	1341	352	352		
55	0	1	670	2100	670	46	151	872	1687	872	56	364	
		2	1729	1729	314	314		1448	1448	295	295		
60	5	1	696	2198	696	46	156	829	1931	829	46	386	
		2	1808	1808	309	309		1575	1575	242	242		
65	25	1	793	2302	793	46	161	840	2208	840	46	409	
		2	1928	1928	339	339		1748	1748	219	219		
70	45	1	1180	2428	1180	46	167	839	2509	839	46	433	
		2	2051	2051	366	366		1929	1929	187	187		

**Caption**

TH: Tower height  
ALS: Jib position  
ZB: Central ballast  
H: Horizontal load

# WOLFFKRAN

Static data

## 12.1.19 Slewing section with 70 m Jib on UW4120

Slewing section with 70 m Jib on UW4120

Slewing tower crane without climbing frame

X Stationary  
Mobile

Corner distance: 12.0 m x 12.0 m

TH	ZB	ALS	Crane in service					Crane out of service				
			Slewing torque:					Wind region:				
			750 kNm					C25				
			Corner loads					Corner loads				
[m]	[t]		A [kN]	B [kN]	C [kN]	D [kN]	H [kN]	A [kN]	B [kN]	C [kN]	D [kN]	H [kN]
20	0	1	585	1597	585	46	113	703	984	703	422	220
		2	1321	1321	335	335		902	902	504	504	
25	0	1	605	1655	605	46	118	728	1073	728	382	241
		2	1371	1371	335	335		972	972	484	484	
30	0	1	623	1718	623	46	123	753	1170	753	335	262
		2	1422	1422	333	333		1048	1048	457	457	
35	0	1	639	1786	639	46	128	777	1276	777	279	283
		2	1476	1476	329	329		1130	1130	425	425	
40	0	1	651	1860	651	46	134	802	1390	802	214	304
		2	1531	1531	323	323		1218	1218	386	386	
45	0	1	661	1939	661	46	139	827	1513	827	141	326
		2	1589	1589	314	314		1312	1312	342	342	
50	0	1	668	2024	668	46	144	852	1646	852	57	349
		2	1649	1649	304	304		1413	1413	290	290	
55	0	1	672	2116	672	46	149	794	1871	794	46	371
		2	1712	1712	290	290		1522	1522	231	231	
60	10	1	722	2215	722	46	154	765	2129	765	46	394
		2	1803	1803	299	299		1663	1663	189	189	
65	30	1	818	2321	818	46	159	773	2410	773	46	417
		2	1921	1921	330	330		1837	1837	165	165	
70	55	1	935	2436	935	46	164	795	2716	795	46	441
		2	2056	2056	370	370		2032	2032	144	144	

**Caption**

TH: Tower height  
ALS: Jib position  
ZB: Central ballast  
H: Horizontal load

# WOLFFKRAN

Static data

## 12.1.20 Slewing section with 75 m Jib on UW4120

Slewing section with 75 m Jib on UW4120

Slewing tower crane without climbing frame

X Stationary  
Mobile

Corner distance: 12.0 m x 12.0 m

TH	ZB	ALS	Crane in service					Crane out of service				
			Slewing torque:					Wind region:				
			750 kNm					C25				
			Corner loads					Corner loads				
[m]	[t]		A [kN]	B [kN]	C [kN]	D [kN]	H [kN]	A [kN]	B [kN]	C [kN]	D [kN]	H [kN]
20	0	1	576	1615	576	46	109	704	1015	704	392	228
		2	1277	1277	330	330		924	924	483	483	
25	0	1	596	1674	596	46	115	728	1105	728	351	248
		2	1325	1325	331	331		995	995	462	462	
30	0	1	614	1738	614	46	120	753	1203	753	303	269
		2	1376	1376	330	330		1071	1071	435	435	
35	0	1	629	1807	629	46	125	778	1309	778	246	291
		2	1428	1428	327	327		1154	1154	402	402	
40	0	1	641	1882	641	46	130	803	1424	803	181	312
		2	1483	1483	322	322		1242	1242	363	363	
45	0	1	650	1962	650	46	135	827	1548	827	107	334
		2	1540	1540	315	315		1337	1337	318	318	
50	0	1	657	2049	657	46	140	829	1705	829	46	357
		2	1598	1598	306	306		1439	1439	265	265	
55	5	1	685	2142	685	46	145	784	1943	784	46	379
		2	1672	1672	306	306		1560	1560	218	218	
60	25	1	784	2242	784	46	151	803	2203	803	46	402
		2	1786	1786	342	342		1727	1727	201	201	
65	40	1	855	2350	855	46	156	786	2487	786	46	425
		2	1891	1891	362	362		1889	1889	163	163	

**Caption**

TH: Tower height  
ALS: Jib position  
ZB: Central ballast  
H: Horizontal load

12.1.21 Slewing section with 80 m Jib on UW4120

Slewing section with 80 m Jib on UW4120

Slewing tower crane without climbing frame

X Stationary  
Mobile

Corner distance: 12.0 m x 12.0 m

			Crane in service					Crane out of service					
			Slewing torque: 750 kNm					Wind region: C25					
TH	ZB	ALS	Corner loads					Corner loads					
[m]	[t]		A	B	C	D	H	A	B	C	D	H	
			[kN]	[kN]	[kN]	[kN]	[kN]	[kN]	[kN]	[kN]	[kN]	[kN]	[kN]
20	10	1	630	1628	630	46	111	468	1175	468	46	236	
		2	1304	1304	212	212		1020	1020	447	447		
25	10	1	649	1689	649	46	117	758	1229	758	287	256	
		2	1348	1348	218	218		1091	1091	425	425		
30	10	1	666	1754	666	46	122	783	1328	783	238	277	
		2	1396	1396	370	370		1168	1168	397	397		
35	10	1	680	1824	680	46	127	808	1435	808	180	298	
		2	1449	1449	366	366		1251	1251	364	364		
40	10	1	691	1900	691	46	132	832	1551	832	113	320	
		2	1503	1503	361	361		1341	1341	324	324		
45	10	1	700	1982	700	46	137	849	1685	849	46	342	
		2	1560	1560	354	354		1437	1437	277	277		
50	10	1	705	2070	705	46	142	788	1906	788	46	365	
		2	1620	1620	344	344		1539	1539	224	224		
55	10	1	708	2165	708	46	147	716	2147	716	46	387	
		2	1681	1681	332	332		1650	1650	163	163		
60	30	1	806	2267	806	46	153	734	2411	734	46	410	
		2	1796	1796	367	367		1818	1818	145	145		
65	55	1	926	2376	926	46	158	765	2699	765	46	433	
		2	1926	1926	411	411		2006	2006	131	131		

**Caption**

TH: Tower height  
ALS: Jib position

ZB: Central ballast  
H: Horizontal load