

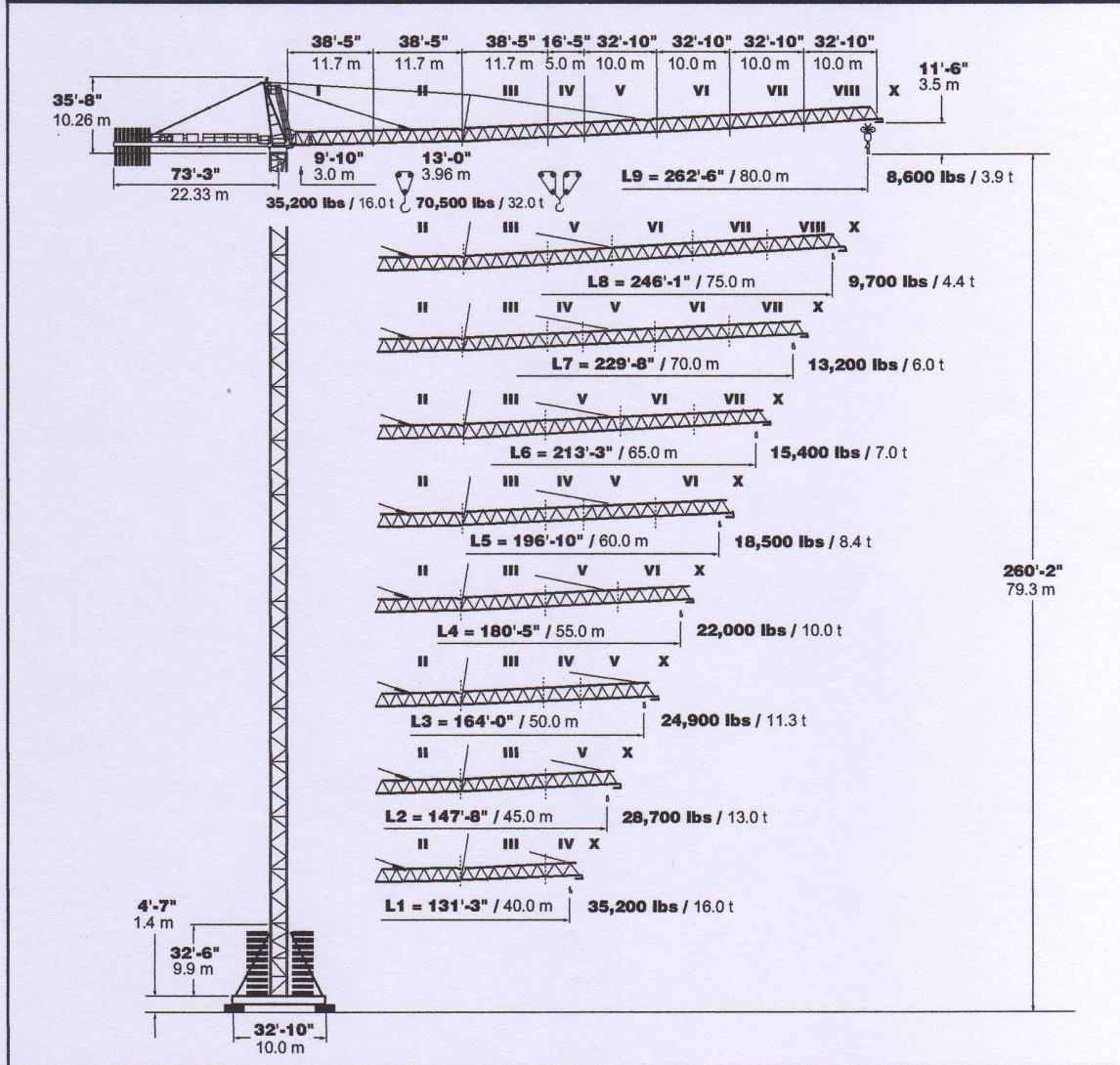

PEINER SK 575

Hammerhead Tower Crane
35,200-70,500 lbs. (16-32 t)
Lifting Capacity

SPECIFICATIONS



simple, available and
cost effective™

Machines shown may have optional equipment.

BIGGE



This information is for reference use only. Operators manual should be consulted and adhered to. Please contact Bigge Crane and Rigging Co. at 888-337-BIGGE or email towers@bigge.com for further information.



BIGGE

PEINER SK 575

Combinations of tower section, tower heights, base ballast

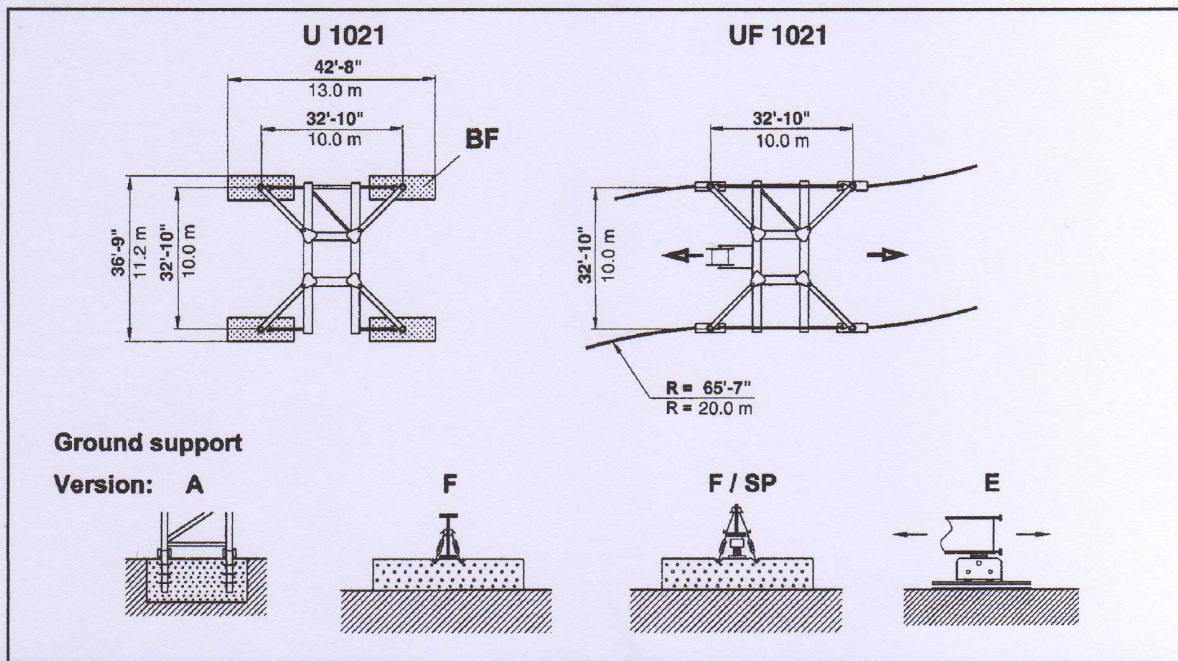
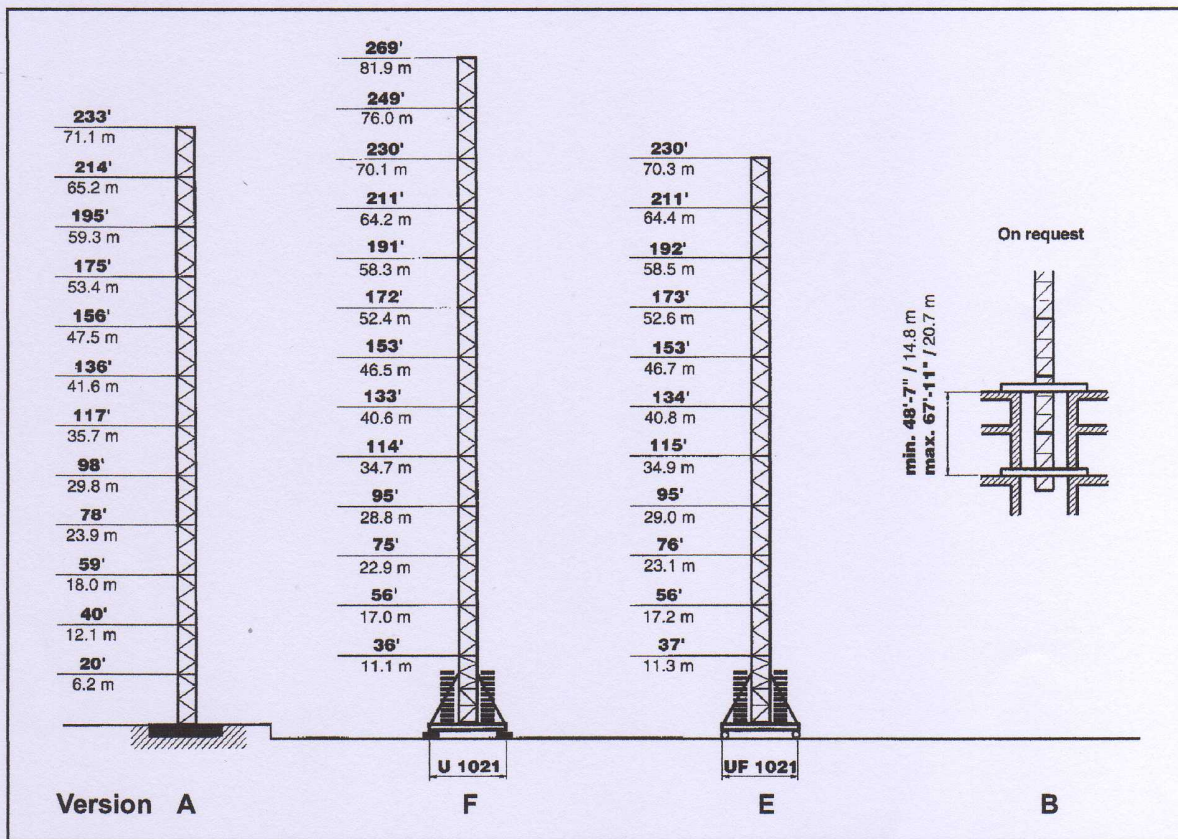

PEINER SK 575 Radius and Capacity

Jib	Max Capacity from		Radius																	
	ft. m	ft. m	ft/m	4-Part line max. 70,500 lbs. max 32.0 t							2-Part line max. 35,200 lbs. max. 16.0 t			Radius - 3'-4"/1.0 m Capacity - 3086 kips/1.41 t						
	9'-10" to 3.0 m to	13'-0" to 3.96 m to	45'-11" 14.0	52'-6" 16.0	59'-1" 18.0	65'-7" 20.0	76'-9" 24.0	91'-10" 28.0	98'-5" 30.0	114'-10" 35.0	131'-3" 40.0	147'-8" 45.0	164'-0" 50.0	180'-5" 55.0	196'-10" 60.0	213'-3" 65.0	229'-8" 70.0	246'-1" 76.0	262'-6" 80.0	
L9	262'-6" 80.0	86'-1" 26.25 m	45'-3" 13.79 m	69224 31.4	58862 26.7	50882 23.1	44533 20.2	35494 16.1	32760 14.9	30247 13.7	25243 11.4	21495 9.75	18607 8.44	16314 7.40	14440 6.55	12875 5.84	11552 5.24	10428 4.73	9458 4.29	8598 3.90
L8	246'-1" 75.0	87'-8" 26.72 m	46'-7" 14.20 m	70547 32.0	61067 27.7	52822 24.0	46296 21.0	36817 16.7	33422 15.2	30864 14.0	25772 11.7	21980 9.97	19026 8.63	16689 7.57	14771 6.70	13183 5.98	11839 5.37	10692 4.85	9700 4.40	
L7	229'-10" 70.0	102'-4" 31.18 m	53'-0" 16.15 m	70547 32.0	70547 32.0	61883 28.1	54453 24.7	43851 19.8	35979 16.3	35273 16.0	30886 14.0	26423 11.99	22994 10.43	20260 9.19	18011 8.17	16138 7.32	14572 6.61	13228 6.00		
L6	213'-3" 65.0	106'-11" 32.58 m	56'-3" 17.15 m	70547 32.0	70547 32.0	66578 30.2	58542 26.6	46958 21.3	38911 17.7	35714 16.2	32498 14.7	27844 12.63	24250 11.00	21362 9.69	19026 8.63	17086 7.75	15432 7.00			
L5	196'-10" 60.0	114'-1/2" 34.76 m	60'-1" 18.31 m	70547 32.0	70547 32.0	70547 32.0	63492 28.8	50928 23.1	42306 19.2	38867 17.6	34987 15.9	30026 13.62	26168 11.87	23104 10.48	20591 9.34	18519 8.40				
L4	180'-5" 55.0	120'-7" 36.75 m	63'-0" 19.20 m	70547 32.0	70547 32.0	70547 32.0	67240 30.5	54012 24.5	44907 20.4	41292 18.7	35273 16.0	32011 14.52	27954 12.68	24691 11.20	22046 10.00					
L3	164'-1" 50.0	121'-51/2" 37.02 m	64'-0" 19.01 m	70547 32.0	70547 32.0	70547 32.0	68563 31.1	55115 25.0	45833 20.8	42152 19.1	35273 16.0	32297 14.65	28175 12.78	24912 11.30						
L2	147'-8" 15.0	123'-3" 37.56 m	65'-7" 20.00 m	70547 32.0	70547 32.0	70547 32.0	70547 32.0	56878 25.8	47266 21.4	43496 19.7	35935 16.3	32826 14.89	28660 13.00							
L1	131'-3" 40.0	124'-0" 37.80 m	86'-10" 20.37 m	70547 32.0	70547 32.0	70547 32.0	70547 32.0	57981 26.3	48347 21.9	44489 20.2	36816 16.7	35273 16.00								

PEINER SK 575 Speeds and Counterweight

Speeds

FU 9-320/4		v = 0 → ~260 fpm (80 m / min.)	1 x 12.2 HP 1 x 9.0 kW					
SR 10-190/4		v = 0 → ~120 fpm (36 m / min.)	4 x 12.2 HP 4 x 9.0 kW					
KWB 120/4		v = 0 → 0.9 min ⁻¹ (rpm)	L1 - L4 L5 - L9 2 x 11.4 HP 2 x 8.4 kW 3 x 11.4 HP 3 x 8.4 kW					
HK max. = 720' / 220 m								
5-Layers								
Type SR WB 102- 160/4F ~160 HP (120.0 kW)		2-Part Line	490 fpm 150 m/min	7700 lbs 3500 kg	4-Part Line	245 fpm 75 m/min	15,400 lbs 7000 kg	Total motor output without SR 10-190/4 ~ 200 HP ~ 150 kW
			315 fpm 96 m/min	13,200 lbs 6000 kg		158 fpm 48 m/min	26,400 lbs 12 000 kg	
			195 fpm 60 m/min	22,000 lbs 10 000 kg		98 fpm 30 m/min	44,000 lbs 20 000 kg	
			125 fpm 38 m/min	35,300 lbs 16 000 kg		63 fpm 19 m/min	70,600 lbs 32 000 kg	
								Connected power 170 kVA

Counterweight

Jib	L1	L2	L3	L4	L5	L6	L7	L8	L9
Counterweight BG	50,800 lbs 23 150 kg	54,400 lbs 24 800 kg	57,600 lbs 26 250 kg	61,200 lbs 27 900 kg	68,000 lbs 31 000 kg	64,400 lbs 29 350 kg	68,000 lbs 31 000 kg	64,400 lbs 29 350 kg	68,000 lbs 31 000 kg
	1 x 3200 lbs 1 x 1450 kg		1 x 3200 lbs 1 x 1450 kg			1 x 3200 lbs 1 x 1450 kg		1 x 3200 lbs 1 x 1450 kg	
	7 x 6800 lbs 7 x 3100 kg	8 x 6800 lbs 8 x 3100 kg	8 x 6800 lbs 8 x 3100 kg	9 x 6800 lbs 9 x 3100 kg	10 x 6800 lbs 10 x 3100 kg	9 x 6800 lbs 9 x 3100 kg	10 x 6800 lbs 10 x 3100 kg	9 x 6800 lbs 9 x 3100 kg	10 x 6800 10 x 3100 kg

BIGGE



This information is for reference use only. Operators manual should be consulted and adhered to.
Please contact Bigge Crane and Rigging Co. at 888-337-BIGGE or email towers@bigge.com for further information.



BIGGE

PEINER SK 575 Dimensions and transport weights

See operating manual for mounting weights

	Designation	Diagram	Dimensions (ft / m)			Weight lbs / t		
			l	b	h			
1	Jib		39'-0" 11.89	6'-6" 1.97	6'-11" 2.12	7490 3.40		
	Section II		40'-6" 12.34	6'-6" 1.97	7'-3" 2.21	8860 4.02		
	Section III		38'-10" 11.84	6'-6" 1.97	7'-7" 2.30	5420 2.46		
	Section IV		18'-8" 5.69	6'-6" 1.97	6'-10" 2.09	5360 2.43		
	Section V		35'-0" 10.68	6'-6" 1.97	6'-11" 2.11	5200 2.36		
	Section VI		35'-5" 10.79	6'-6" 1.97	6'-4" 1.93	4280 1.94		
	Section VII		33'-6" 10.20	6'-6" 1.97	6'-3" 1.90	2760 1.25		
	Section VIII		33'-5" 10.19	6'-6" 1.97	6'-2" 1.88	1700 0.77		
	Jib Tip		6'-8" 2.02	4'-6" 1.37	2'-11" .88	660 0.30		
	2		Tower Top cpl.		27'-1" 8.26	6'-5" 1.96	6'-6" 3.1	9590 4.35
	3		Turntable cpl.		11'-9" 3.58	7'-1" 2.17	7'-5" 2.27	24,100 10.93
	Cab		5'-5" 1.65	3'-7" 1.10	7'-2" 2.18	1040 0.47		
4	Support, railing, electrical panel		11'-8" 3.55	6'-7" 2.00	6'-5" 1.95	2050 0.93		
5	Counterjib		G 2	38'-10" 11.85	7'-5" 2.25	5'-11" 1.80	7500 3.40	
			G 1	31'-1" 9.48	6'-8" 2.03	5'-8" 1.72	6030 2.74	
6	Counterjib ballast		BG	5'-11" 1.81	0'-8" 0.19	10'-4" 3.14	3200 1.45	
				5'-11" 1.81	0'-8" 0.19	15'-4" 4.68	6800 3.10	
7	Tower section		TS 213.1	19'-6" 5.95	7'-10" 2.39	7'-10" 2.38	9790 4.44	
			TSV 213	39'-4" 12.00	10'-4" 3.15	10'-4" 3.15	31,090 14.10	
8	Rail mounted undercarriage with electrical panel			44'-0" 13.40	9'-6" 2.90	3'-9" 1.15	38,440 17.10	
				8'-2" 2.50	2'-8" 0.82	2'-11" 0.89		
9	Central ballast block		13'-5" 4.50	6'-1" 2.05	1'-2" 0.40	14,550 6.60		
10	Foundation block		9'-0" 3.00	3'-7" 1.20	2'-6" 0.75	14,550 6.60		
11	Accessories							

For more information, product demonstration, or details on lease and rental plans, please contact your local Terex Towers Distributor.

We reserve the right to amend these specifications at any time without notice. The only warranty applicable is our standard written warranty applicable to the particular product and sale. We make no other warranty, expressed or implied.

Bigge Crane and Rigging Co.

10700 Bigge Avenue
San Leandro, CA 94577
Phone: (888) 337-BIGGE or (510) 638-8100
Fax: (510) 639-4053
Email: towers@bigge.com
Web site: www.biggetowercrane.com

TT-111

©Terex Cranes, Inc. 2000

TEREX TOWERS

202 Raleigh Street
Wilmington, NC 28412 USA
(910) 395-8500 • FAX: (910) 395-8547
E-mail: wilmington@terexlifting.com

www.terexlift.com

Litho in U.S.A.

5K500J90

BIGGE



This information is for reference use only. Operators manual should be consulted and adhered to. Please contact Bigge Crane and Rigging Co. at 888-337-BIGGE or email towers@bigge.com for further information.



BIGGE