

3

**TECHNICAL SPECIFICATIONS**

The chapter describes the technical specifications and characteristics of the CTL 130 tower crane with luffing jib.

**3.1 CRANE CLASSIFICATION**

Standards for structural calculations of the crane: DIN 15018; DIN 18800; DIN 1055; DIN 17100; C.N.R. 10011/85

Machine class:

according to standard DIN 15018 this machine belongs to class H1 - B3.

Standards for the electrical components:

CEI - EN 60204 - 1.

**3.2 JIB RANGE AND CONFIGURATIONS**

The dimensions are expressed in meters

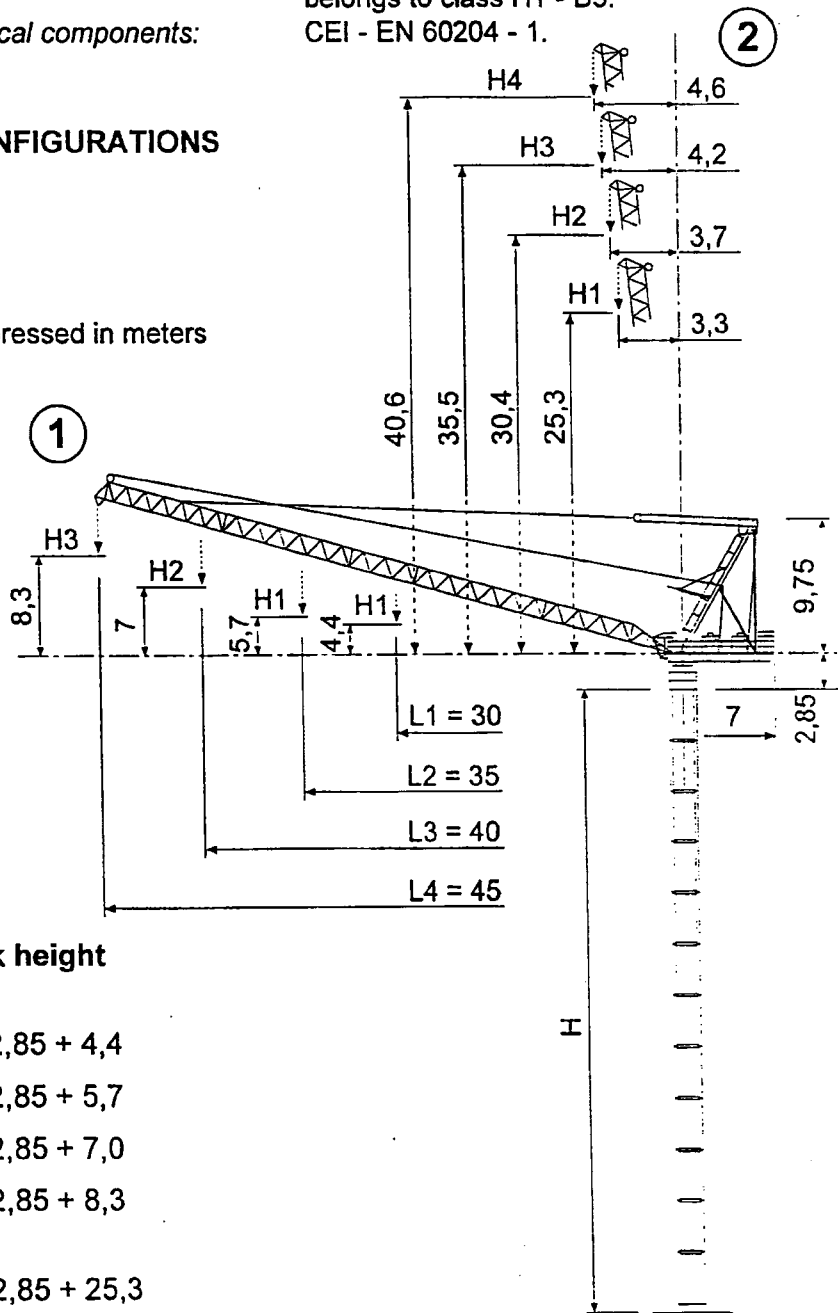

**Under hook height**

$H1 = H + 2,85 + 4,4$

$H2 = H + 2,85 + 5,7$

①  $H3 = H + 2,85 + 7,0$

$H4 = H + 2,85 + 8,3$

$H1 = H + 2,85 + 25,3$

$H2 = H + 2,85 + 30,4$

②  $H3 = H + 2,85 + 35,5$

$H4 = H + 2,85 + 40,6$

Fig. 3.1

TOWER H20

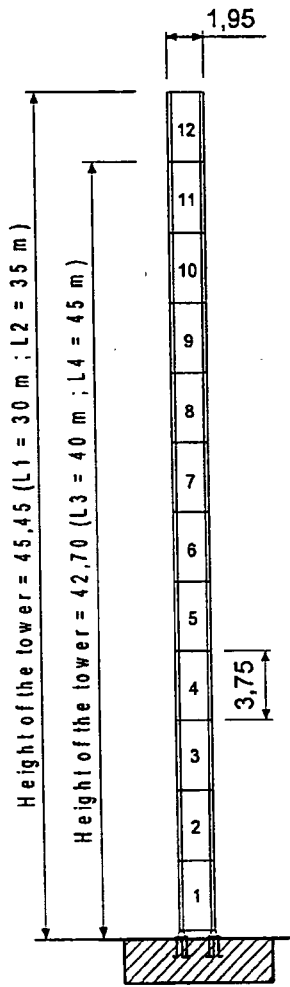

R

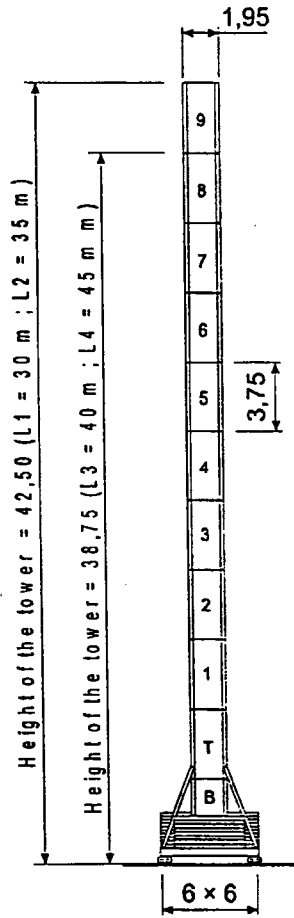

F - T

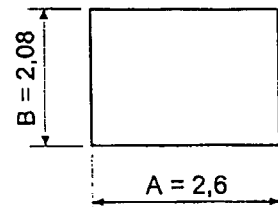
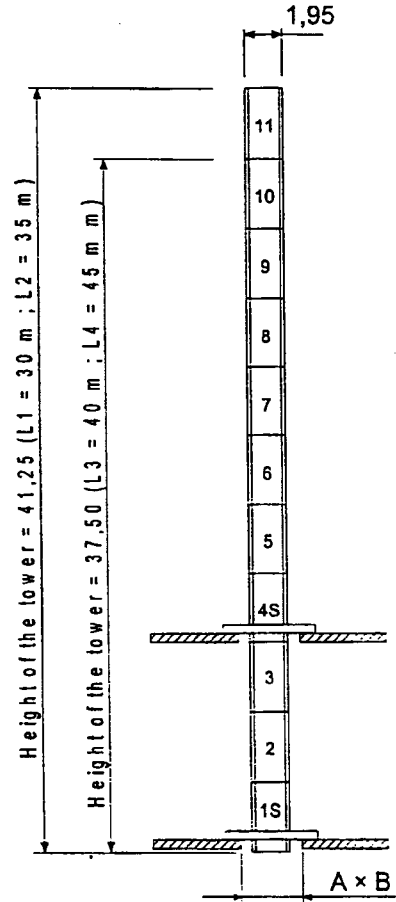

CLIMBING

The dimensions are expressed in meters

Fig. 3.2

**3.3 JIB RANGE AND CAPACITY**



**2 falls**

Jib range [m]	Capacity [kg] for jib long:				Jib length	Max. capacity	Range	Falls
	30 m	35 m	40 m	45 m				
20	8000	8000	8000	8000	45 m	8000 kg	20.6 m	II
22	8000	8000	7710	7390	40 m	8000 kg	21.2 m	II
24	7280	7390	6870	6590	35 m	8000 kg	22.6 m	II
26	6480	6640	6170	5920	30 m	8000 kg	22.4 m	II
28	5800	6000	5560	5340				
30	5200	5420	5040	4840				
33		4710	4370	4200				
35		4300	4000	3840				
38			3490	3360				
40			3200	3070				
43				2710				
45				2500				

**Luffing angle - Jib Conversion Table**

Angle	Jib 45 m		Jib 40 m		Jib 35 m		Jib 30 m	
	Jib	Capacity [kg]	Jib	Capacity [kg]	Jib	Capacity [kg]	Jib	Capacity [kg]
	[m]	ll falls	[m]	ll falls	[m]	ll falls	[m]	ll falls
15°	45,00	2500	40,00	3200	35,00	4300	30,00	5200
16°	44,79	2522	39,82	3226	34,84	4331	29,86	5238
17°	44,57	2546	39,62	3254	34,67	4365	29,72	5280
18°	44,33	2571	39,41	3283	34,49	4401	29,56	5324
19°	44,08	2598	39,19	3315	34,29	4440	29,40	5371
20°	43,82	2627	38,95	3349	34,09	4482	29,22	5422
21°	43,54	2658	38,71	3385	33,88	4526	29,04	5476
22°	43,25	2691	38,45	3424	33,65	4572	28,85	5533
23°	42,95	2725	38,18	3464	33,42	4622	28,65	5593
24°	42,63	2762	37,90	3507	33,17	4674	28,44	5657
25°	42,30	2801	37,61	3552	32,92	4729	28,23	5725
26°	41,96	2841	37,30	3600	32,65	4788	28,00	5796
27°	41,61	2884	36,99	3651	32,38	4849	27,77	5871
28°	41,24	2930	36,66	3704	32,09	4914	27,52	5951
29°	40,86	2977	36,33	3760	31,80	4983	27,27	6034
30°	40,46	3028	35,98	3819	31,50	5054	27,01	6122
31°	40,06	2080	35,62	3881	31,18	5130	26,74	6214
32°	39,64	3136	35,25	3946	30,86	5210	26,47	6311
33°	39,21	3194	34,87	4015	30,53	5293	26,18	6414
34°	38,77	3255	34,48	4087	30,18	5381	25,89	6521
35°	38,32	3320	34,07	4162	29,83	5473	25,59	6633
36°	37,85	3388	33,66	4242	29,47	5570	25,28	6752
37°	37,37	3459	33,24	4325	29,10	5672	24,97	6876
38°	36,89	3533	32,80	4413	28,73	5779	24,65	7007
39°	36,39	3612	32,36	4505	28,34	5891	24,32	7144
40°	35,88	3694	31,91	4601	27,94	6009	23,98	7288
41°	35,36	3781	31,45	4703	27,54	6133	23,63	7440
42°	34,82	3872	30,97	4810	27,13	6264	23,28	7599
43°	34,28	3968	30,49	4923	26,71	6401	22,92	7767
44°	33,73	4068	30,00	5041	26,28	6545	22,56	7943
45°	33,17	4175	29,50	5166	25,84	6697	22,18	8000
46°	32,59	4286	28,99	5297	25,40	6857	21,80	8000
47°	32,01	4404	28,48	5435	24,95	7026	21,42	8000
48°	31,42	4529	27,95	5581	24,49	7204	21,02	8000
49°	30,81	4660	27,41	5735	24,02	7392	20,62	8000
50°	30,20	4798	26,87	5898	23,54	7590	20,22	8000
52°	28,95	5100	25,76	6251	22,57	8000	19,39	8000
54°	27,66	5438	24,62	6649	21,58	8000	18,53	8000
56°	26,34	5820	23,45	7096	20,55	8000	17,66	8000
58°	24,99	6253	22,24	7604	19,50	8000	16,76	8000
60°	23,61	6747	21,02	8000	18,43	8000	15,84	8000
62°	22,20	7314	19,76	8000	17,33	8000	14,90	8000
64°	20,76	7972	18,49	8000	16,22	8000	13,95	8000
66°	19,29	8000	17,19	8000	15,08	8000	12,97	8000
68°	17,81	8000	15,86	8000	13,93	8000	11,99	8000
70°	16,30	8000	14,52	8000	12,75	8000	10,98	8000
72°	14,77	8000	13,17	8000	11,57	8000	9,97	8000
84°	5,28	8000	4,74	8000	4,20	8000	3,66	8000

**3.4 WINCH TABLE**

Hoisting	Speed	Capacity	Power		
	m/min	kg	HP	kW	
<b>AWL- R 7008</b>					
	36	8000			
	50	5600			
	68	4000	75	55	440 m max
	95	2800			> 440 m consult Comedil
	110	1200			

	Type	Speed	Power	
Luffing	AWL-R 7000	1,5 min	74 HP	54 kW
Slewing	DCU	0 - 0,8 r.p.m.	2 × 9,3 HP	2 × 6,8 kW
Travelling (example)	2RG 4M3	0 - 24 m/min	4 × 4 HP	4 × 3 kW

**3.5 ELECTRIC POWER SUPPLY**

Required electric power *	Winches	Three phase current
160 kVA	AWL-R 7000 + AWL-R 7008	400 + 440 V - 50 + 60 Hz

\* Required electric power refers to static crane (not travelling version).

**3.6 WIRE ROPE TABLE**

Wire rope	Diameter [mm]	Breaking strain [kN]
Hoisting	16	211
Luffing	18	273